

A beam collimation checker that can be used with low coherence light.

- The state of the beam can be evaluated only by inserting the unit into the optical path, the troubles of optical alignment and the time can be greatly reduced, and a higher quality light beam can be obtained.
- Can be used with low coherent light (coherence length: 10 μm or more) that could not be used with conventional collimation checkers.
- Corresponds to the wavelength of the light source up to near infrared (400 nm to 1100 nm)
- It is a composite product of collimation checker main unit (including USB camera) and USB 3.0 cable (1.5 m) and can be used immediately after purchase. ※ PC will be prepared by customers.



Specifications	
Part Number	SPVNIR-05-CS
Wavelength Range [nm]	400~1100
Input Beam Diameter [mm]	φ3~ ※Aperture size is φ10
CMOS camera interface	USB3.0
Material of Shearing Plate	BK7
Plate Thickness [mm]	0.5
Fringe Spacing [mm]	0.37
Material	Aluminum (Black Anodized)

Software specifications	
Part Number	OSCAMS
Measurement and output parameters	<ul style="list-style-type: none"> • Fringe rotation angle (deg) [Resolution 0.1deg] • Radius of curvature (m) [Resolution 0.1m] • Beam divergence (half angle) (mrad) [Resolution 0.01mrad] • Power (λ) [Resolution 0.1]
Functions	<ul style="list-style-type: none"> • OK/NG judgment (parameter selection, upper / lower limit settable) • Automatic setting of evaluation area circle (manual setting is also possible) • Data storage (can add comment) • Save images • Parameter file editing • Camera property change • Tabular output of statistical data • Chart output of statistical data • Statistical value output (average, standard deviation, pass rate)

Supported OS: Windows® 7 (32/64 bit) / 10 (32/64 bit)

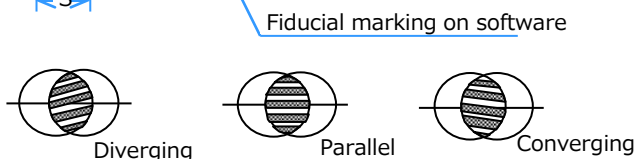
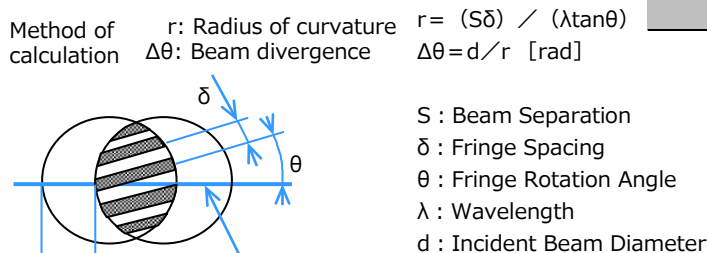

Guide

- ▶ Please download and install Automated Collimation Measurement Software (OSCAMS) from our website.
- ▶ Post is not included. Please purchase M6 threaded Post and Post stand from our catalog. The size of the M6 hole meets our standard. When post is prepared by customer, please make sure M6 thread length is less than 5 mm.
- ▶ The USB camera adapter unit has a filter case. An optical filter such as ND filter (prepared by customer) can be inserted.

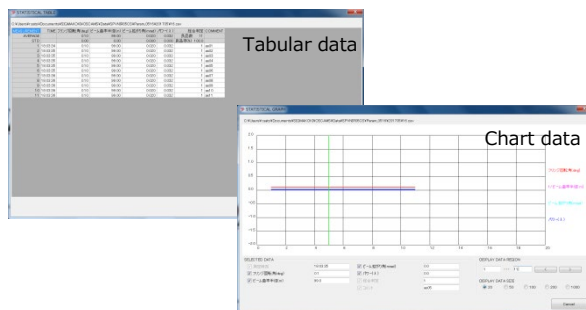

Measurement screen

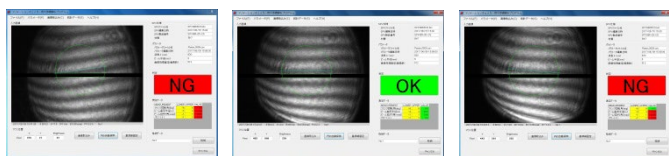

Beam Collimation checkers with optical path compensation

SPVNIR-05-CS **NEW**

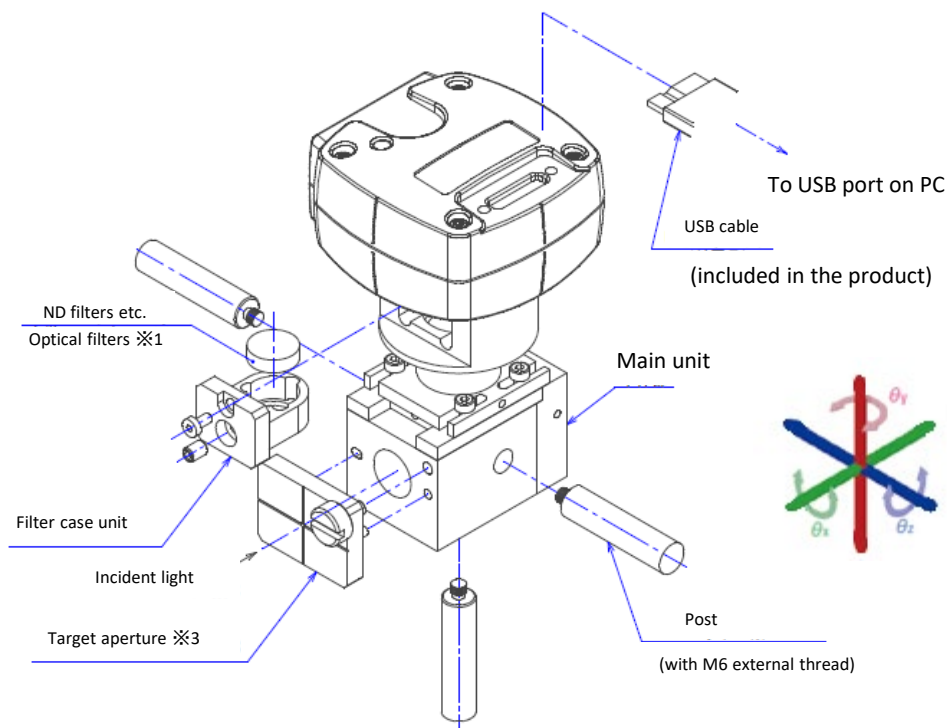

- ※1 Applicable optical filter size: ϕ 9 mm to ϕ 10 mm, thickness 3 mm to 5 mm (Please prepare by customer if necessary)
- ※2 Post is not included. Please purchase our catalog item RO series (size ϕ 12mm or larger).
- ※3 Target aperture is used when adjusting the position of the main unit. Adjust and fix the main unit so that the light passing through the aperture (ϕ 1 mm) is located approximately at the center of the camera field of view.



Outline Drawing

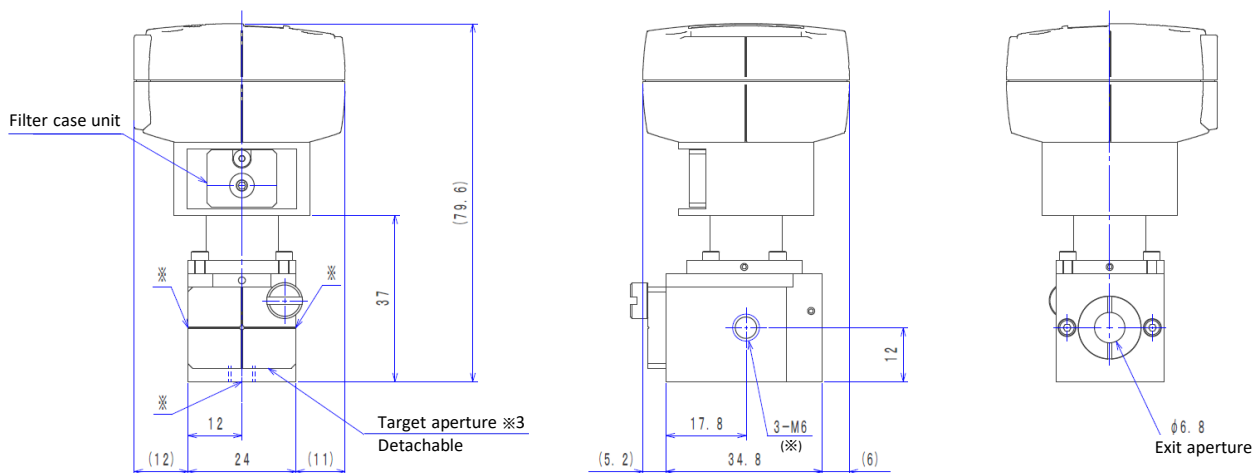

■ Cautions

- ▶ When inserting this product and optics into the laser beam path, there is a danger that the laser beam will be reflected towards the operator, so please observe safety precautions for the laser light (wearing laser safety goggles etc.).
- ▶ Even if this product is inserted into the laser beam path, the beam is not blocked and exits from the aperture, so please do not look into the laser beam path.
- ▶ Please use under the condition of incident beam power of 10 W/cm² or less (reference value for 1064nm laser). Please use beam sampler (BS4) when exposing to a laser beam which exceeds.
- ▶ When the collimation checker is installed inclined with respect to the optical axis, clear interference fringes may not be observed in some cases. In such a case, by adjusting the collimation checker in the θ_z direction, an angle at which interference fringes can be clearly observed can be found.