

Extensible Stage Controller

(Slave Unit for 2-phase Stepping Motor) HIT-SA-M2

Modular stage control system with Master controller (HIT-MV or HIT-M) and maximum eight slave Axes. Equipped with a 2-phase bipolar stepping motor driver, it can control stages with 2-phase stepping motor.

◦ 2-phase stepping motor stages can be controlled with the same number of division settings as general 5-phase stepping motor stages. (Note 1)



Guide

- ▶ The Stage cable (D15RP cable/D15D15A cable) and Scale cable (GSEF cable) used for existing 5-phase stepping motor stages can be commonly used.
- ▶ The following sample programs can be downloaded from WEB.
 - SG Sample for 32/64-bit Windows® version
 - LabVIEW

Attention

- ▶ The power supply specification of HIT-SA-M2 is DC+24[V] 2[A]. Please prepare a power supply with a rated current of 3[A] (1 axis) to 17[A] (8 axes) depending on the number of stage axes including the Master Unit. The AC-ADP-2427 (AC adapter) must be purchased or provided by the customer.

(Note 1) Only a 2-phase stepping motor with a basic step angle of 1.8[degrees] can drive a stage with the same number of divisions as a 5-phase stepping motor with a basic step angle of 0.72[degrees].

(e.g., if the number of divisions is set to "1" for a 2-phase stepping motor with a basic step angle of 1.8[degrees], one revolution of the motor will result in 500 pulses). For details, please refer to the instruction manual.

Outline Drawing (in: mm)

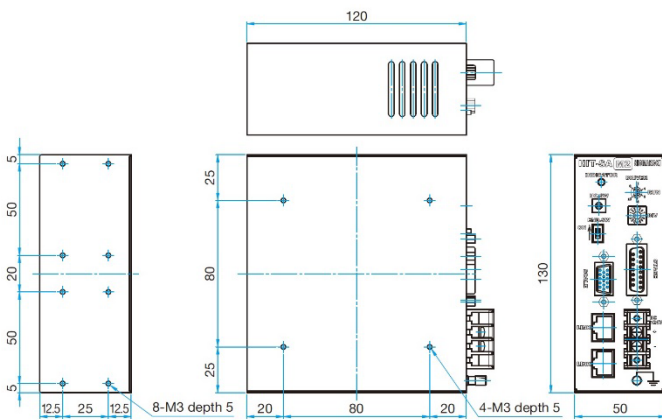

Specifications	
Part Number	HIT-SA-M2
Product Name	Extensible Stage Controller (Slave Unit for 2-phase Stepping Motor)
Supported Master Controllers	HIH-M/HIT-MV

HIT-SA-M2 System Diagram

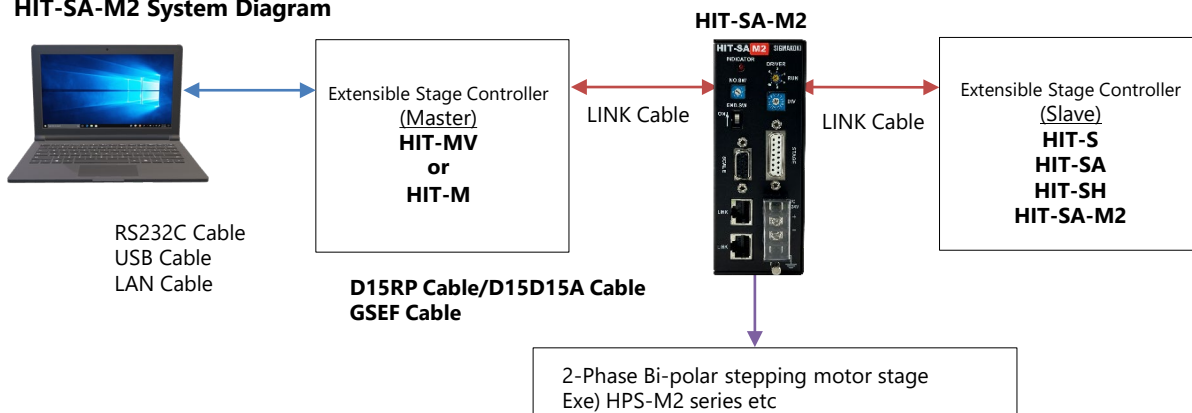

Specifications	
General Specifications	
Power Supply	DC24V 2A
Operating Temperature	5~40°C
Storage Temperature	-20~60°C
Ambient Humidity	20~80%RH(No Condensation)
Weight	0.62kg
External Dimensions (W×H×D)	130×120×50mm

Performance (when used with HIT-MV and HIT-MV)	
Number of Control Axes	Max 8
Max. Driving Speed(F)	0.01~9999999.99[μm/s] (1~500000[PPS])
Min. Driving Speed(S)	0.01~9999999.99[μm/s] (1~500000[PPS])
Maximum Pulses	-134217728 pulse~+134217727 pulse
Acceleration /Deceleration Time (R)	1~1000[ms]
Sensor Input	Origin Sensor/Proximity Sensor/ CW (-) Limit/CCW(+)/Limit (The input logic of each sensor can be switched by a memory switch.)
Interface	Supported Master Controllers (HIT-M/MV)

Driver Specifications(HIT-SA-M2)	
Driving method	2-Phase Bi-polar constant current drive
Driving Electric Current	0.3[A/Phase]~1.8[A/Phase]
Current Down	Half of Driving Current
Division settings[pulse/rotate] (Note1)	1(500), 2(1000), 4(2000), 5(2500), 8(4000), 10(5000), 20(10000), 25(12500), 40(20000), 50(25000), 80(40000), 100(50000), 125(62500), 200(100000), 250(125000) divisions
Fast Transient / Burst Noise	EN61000-4-4(2012) Level 2
Electrostatic Noise	EN61000-4-2(2009) Level 2

(Note1) This is for a 2-phase stepping motor with a basic step angle of 1.8[degrees].

Interface	
GP-IB	—
RS232C	○
USB	(virtual COM port)
Ethernet	○

Optional	
CJ-200A	-
JS-301	-
JB-401	-
JD-101	-
SJT-02	-
MD-400	-

Connector pin assignments (HIT-SA-M2)

• STAGE connector

(Connector:

XM2D-1501(OMRON products) Equivalent product used.

Nº	Description
1	Blue : Motor
2	Red : Motor
3	-
4	Green : Motor
5	Black : Motor
6	GND
7	ORG : Mechanical origin detection
8	+24[V] : Sensor Power Source
9	GND : Electromagnetic Brake
10	+24[V] : Electromagnetic Brake
11	LS(+) : positive side Limit detection
12	LS(-) : negative side Limit detection
13	GND
14	NEAR : proximity detection
15	+24[V] : Sensor Power Source

• SCALE connector

(Connector used: XM4L-1542-112 (manufactured by
OMRON Corporation) or equivalent)

Nº	Description
1	GND
2	GND
3	+5V
4	+5V
5	-
6	-
7	-
8	-
9	Alarm-
10	A+
11	A-
12	B+
13	B-
14	-
15	FG

• LINK connector

(Connector used: modular connector RJ45 or equivalent)

Nº	Description
1	-
2	-
3	DATA+
4	-
5	-
6	DATA-
7	-
8	-