

压电手动XYZ一体式平台

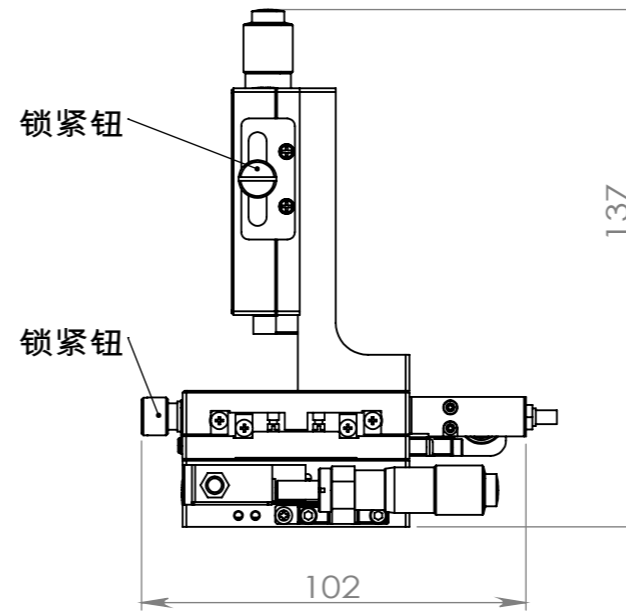

技术指标

型号	PMLT83-60S
台面尺寸mm	60 X 60
轴的类型	XYZ
粗调行程mm	+/-6.5
微调行程	大于30um
微分头的安装位置	侧面
微分头最小读数	0.01mm
压电最小分辨率	20nm以下
导轨形式	钢制导轨
主要材料	铝合金
表面处理	黑色氧化
承载能力	1.0kgf
移动直线度	3um
最大承载俯仰力矩	4.9N.m
最大承载转动力矩	4.9N.m
扭矩刚度	0.3"/N.cm
移动平行度	10um
自重	1.5kg
压电控制模式	旋钮控制 (含控制盒)

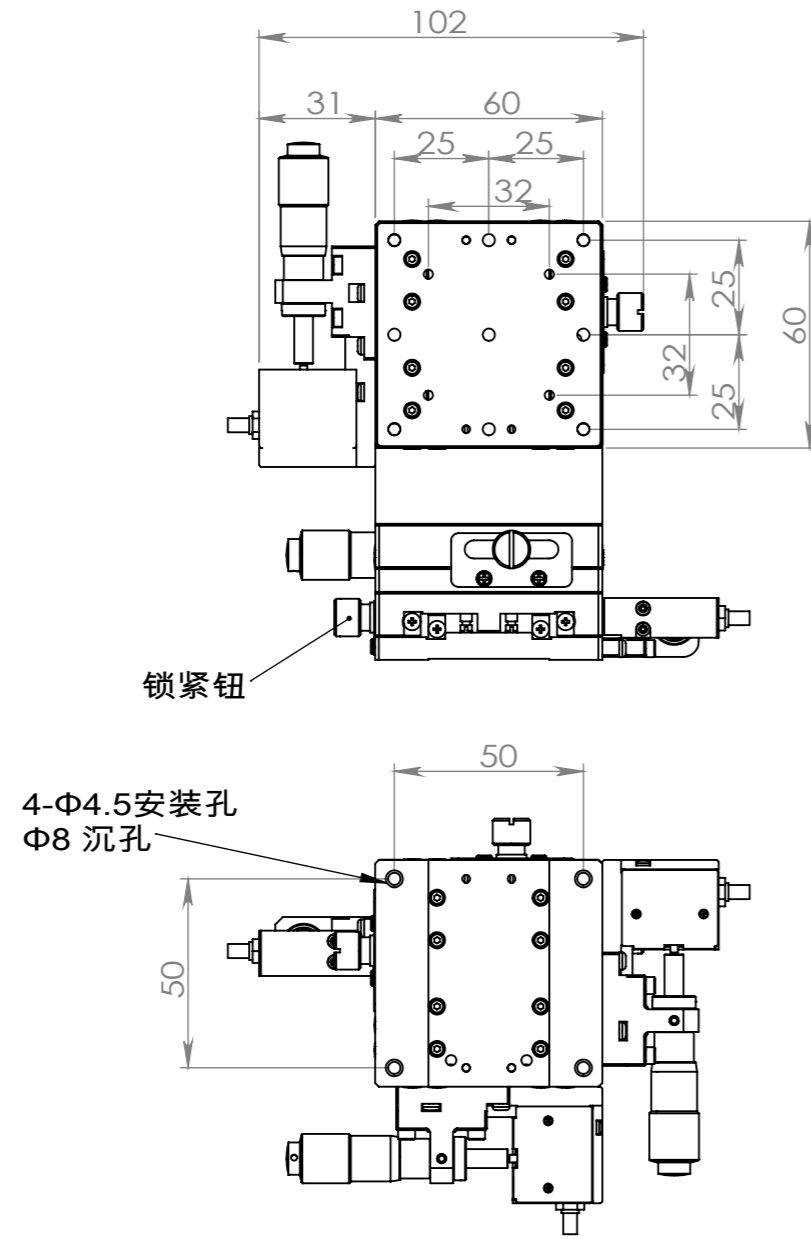
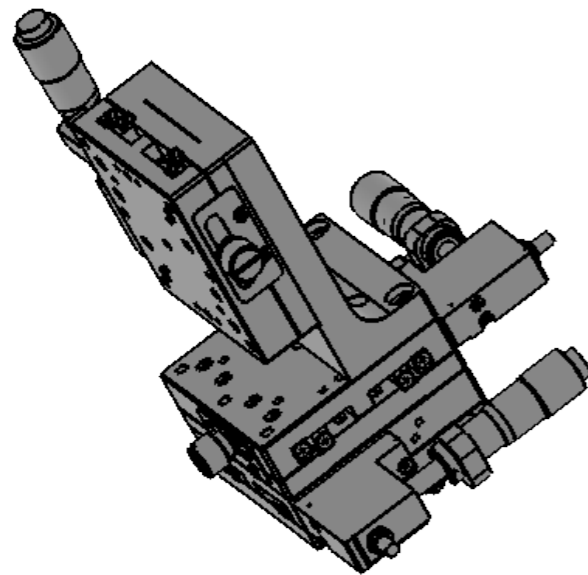

UNLESS OTHERWISE SPECIFIED: DIMENSIONS ARE IN MILLIMETERS		FINISH:		DEBURR AND BREAK SHARP EDGES		DO NOT SCALE DRAWING		REVISION	
SURFACE FINISH: TOLERANCES: LINEAR: ANGULAR:						<p align="center">HOURS www.hours-web.com</p>		TITLE:	
								DWG NO.	
DRAWN	NAME	SIGNATURE	DATE			PMLT83-60S			
CHK'D						SCALE:1:2		SHEET 1 OF 1	
APP'VD									
MFG									
Q.A				MATERIAL:					
				WEIGHT:					