

Compact Stepping Motor Actuators

SGSP-ACT

RoHS

CE

A low price actuator fitted with a high-performance compact stepping motor and precision ground screws. Use to replace micrometer heads on OptoSigma manual stages or mirror holders to motorize them.



- Compatible with all OptoSigma stepper motor controllers.
- Available with 13mm or 25mm travel.

Guide

- ▶ Refer to the list of compatible products. [Reference](#) F020
- ▶ Custom tapped tips can be supplied. Contact our Sales Division for more information.
- ▶ Recommended controllers include the single axis stage controller (GSC-01) and 2 axis stage controllers (GSC-02).
 GSC-01 [Reference](#) G108 [Catalog Code](#) W9042
 GSC-02 [Reference](#) G109 [Catalog Code](#) W9044

Schematic

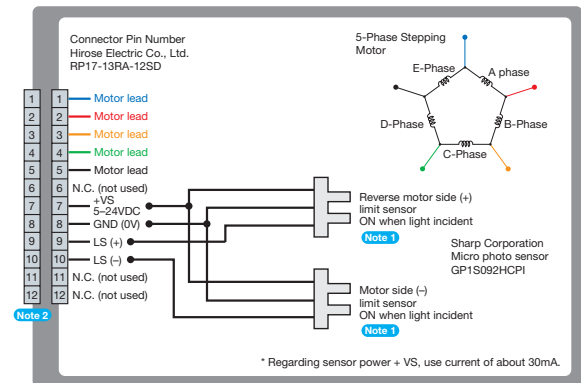

Note 1 The limit sensor on the motor side is the minus limit sensor. Motorized stages are not fitted with origin and origin proximity sensors. Limit sensors are used as origin detection sensors.
Note 2 Compatible cable connector: Hirose Electric Co., Ltd. RP17-13PA-12PC/RP17-PC-122



Common Specifications	
Single-Pulse Travel [μ m] (full step/half step)	1/0.5
Type	5-phase stepping motor 0.35A/phase (Oriental Motor Co., Ltd.)
Motor Part Number	PK513PB-C9 (□20mm)
Feed screw [mm]	Precision ground screw ϕ 4, 0.5mm lead

Outline Drawing

SGSP-13ACT-B0

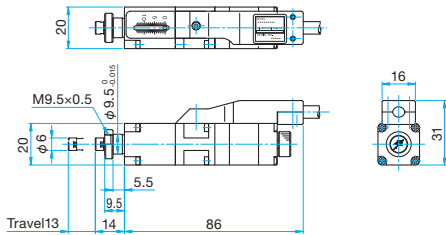

SGSP-13ACTR-B0

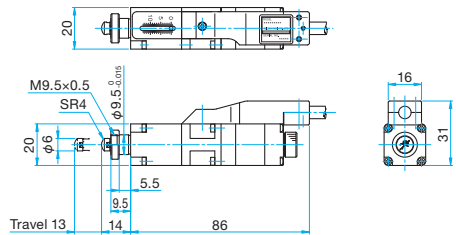

SGSP-25ACT-B0

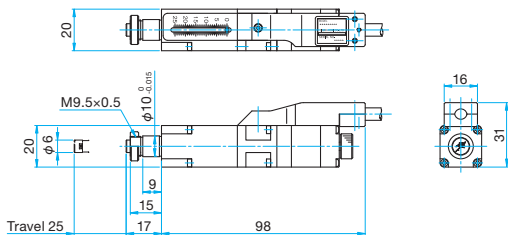

SGSP-25ACTR-B0

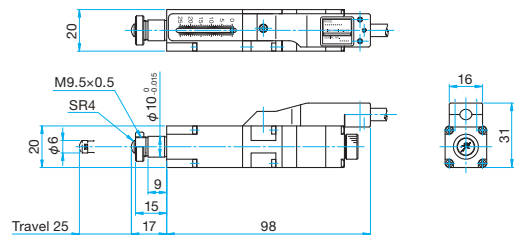

Part Number	Tip Shape	Travel [mm]	Maximum Travel [mm/sec]	Positioning Accuracy [mm]	Positional Repeatability [mm]	Lost Motion [mm]	Load Capacity (Static load) [N]	Weight [kg]
SGSP-13ACT-B0	Flat type	13	2	0.01	0.003	0.005	29.4 (3kgf)	0.16
SGSP-13ACTR-B0	R type	13	2	0.01	0.003	0.005	29.4 (3kgf)	0.16
SGSP-25ACT-B0	Flat type	25	2	0.015	0.003	0.005	29.4 (3kgf)	0.18
SGSP-25ACTR-B0	R type	25	2	0.015	0.003	0.005	29.4 (3kgf)	0.18

Compatible Controllers / Drivers and Cables

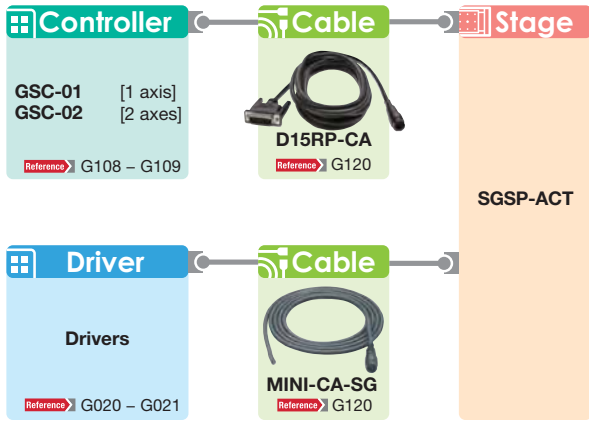

System Chart

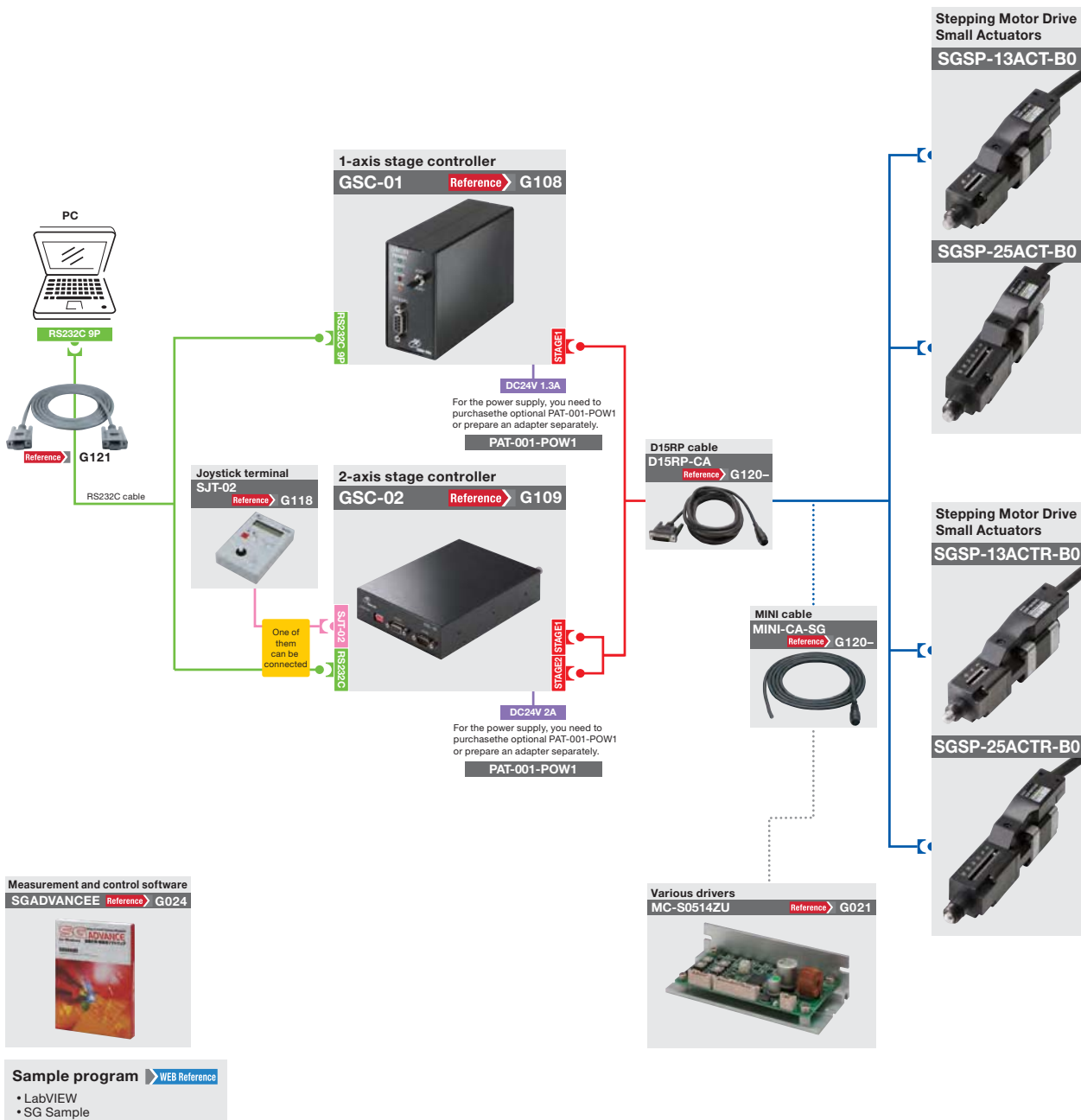

Measurement and control software
 SGADVANCEE Reference G024



Sample program WEB Reference
 • LabVIEW
 • SG Sample

Application Systems

Optics & Optical Coatings

Opto-Mechanics

Bases

Manual Stages

Actuators & Adjusters

MotORIZED Stages

Light Sources & Laser Safety

Index

Micrometer Heads

Differential Micrometer Heads

Fine-pitch Screws

Remote

PKA

ACT

List of Products Compatible with SGSP-ACT

List of Products Compatible with SGSP-13ACT-B0/SGSP-25ACT-B0

Part Number	Products name		Actuator part number (SGSP-ACT series)	Quantity	Adopter
	Products name	Stage size			
TSD Serie					
TSD-401C	X axis Steel Stages	□40mm×40mm	SGSP-13ACT-B0	1	
TSD-401S			SGSP-13ACT-B0	1	Need
TSD-402C			SGSP-13ACT-B0	2	
TSD-403L			SGSP-13ACT-B0	1	
TSD-601C	X axis Steel Stages	□60mm×60mm	SGSP-13ACT-B0	1	
TSD-601S			SGSP-13ACT-B0	1	
TSD-602C			SGSP-13ACT-B0	2	
TSD-603L			SGSP-13ACT-B0	1	
TSD-603			SGSP-13ACT-B0	1	Need
TSD-801C	X axis Steel Stages	□80mm×80mm	SGSP-25ACT-B0	1	Need
TSD-801S			SGSP-25ACT-B0	1	Need
TSD-802C			SGSP-25ACT-B0	2	Need
TSD-1001C			SGSP-25ACT-B0	1	
TSD-1001S	X axis Steel Stages	□100mm×100mm	SGSP-25ACT-B0	1	
TSD-1002C			SGSP-25ACT-B0	2	
TSD-1002S			SGSP-25ACT-B0	2	
TSD-120**			X axis Steel Stages	□120mm×120mm	Travel:±12.5
TAM Series					
TAM-401C	X axis Aluminum Crossed Roller Slide Stages	□40mm×40mm	SGSP-13ACT-B0	1	
TAM-401S			SGSP-13ACT-B0	1	
TAM-402C			SGSP-13ACT-B0	2	
TAM-403L			SGSP-13ACT-B0	1	
TAM-601C	X axis Aluminum Crossed Roller Slide Stages	□60mm×60mm	SGSP-13ACT-B0	1	
TAM-601S			SGSP-13ACT-B0	1	
TAM-602C			SGSP-13ACT-B0	2	
TAM-602S			SGSP-13ACT-B0	2	
TAM-603L			SGSP-13ACT-B0	1	
TAM-1001C	X axis Aluminum Crossed Roller Slide Stages	□100mm×100mm	SGSP-25ACT-B0	1	
TAM-1001S			SGSP-25ACT-B0	1	
TAM-1002C			SGSP-25ACT-B0	2	
TAM-1002S			SGSP-25ACT-B0	2	
MHAN Series					
MHAN-25.4M	Gimbal Beamsplitter Holders (Micrometer Type)	—	SGSP-13ACT-B0	2	Need
MHAN-30M			SGSP-13ACT-B0	2	Need
MHAN-40M			SGSP-13ACT-B0	2	Need
MHAN-50M			SGSP-13ACT-B0	2	Need
MHAN-50.8M			SGSP-13ACT-B0	2	Need
MHAN-60M			SGSP-13ACT-B0	2	Need
LMHB					
LMHB-30M	Topmike Vertical Control Mirror Holders	—	SGSP-13ACT-B0	2	Need
LMHB-50M			SGSP-13ACT-B0	2	Need
LMHB-60M			SGSP-13ACT-B0	2	Need

● Combined with steel extended contact slide stage TSD-403L



Application Systems

Optics & Optical Coatings

Opto-Mechanics

Bases

Manual Stages

Actuators & Adjusters

Motorized Stages

Light Sources & Laser Safety

Index

Micrometer Heads

Differential Micrometer Heads

Fine-pitch Screws

Remote

PKA

ACT

Guide

- ▶ For its cost and lead time, please ask international Sales Division.
- ▶ Please contact us if you want us to mount the actuator with your previously purchased stages / holders..
- ▶ For some products , it would require a special adopter for mounting . Please contact us for further information.