

Vacuum Mirror Holder | VMHG



Low out-gas mirror holders for installing optical system in the high vacuum chamber.

- These can be used for UV laser optical system and in the clean room.
- **Adjustment screw is removable (except for VMHG-12.7). This enables installing electric actuators of remote control device. (Actuators are not included.)**
- Screw hole grooving and vent hole processing are applied to prevent the out-gas emits when forming vacuum.
- BARRIERTA SUPER IS/V is used for the grease of sliding part.



Guide

- ▶ We deliver the item with specialized vacuum packaging to keep its high clean state from the factory to the destination.
- ▶ Please use vacuum screws (VPCB/VAGB) for installing base plates.
- ▶ We provide vacuum pedestal bases (VPST) and posts (VRO).
- ▶ We will produce custom products for the requested specifications.

Attention

- ▶ Specialized nut turning tool (VNS-12) is necessary in removing adjustment screw or equipping actuators. W6112
- ▶ Please open the package in the clean environment. Please do not touch it by your bare hands.

Outline Drawing

VMHG-12.7

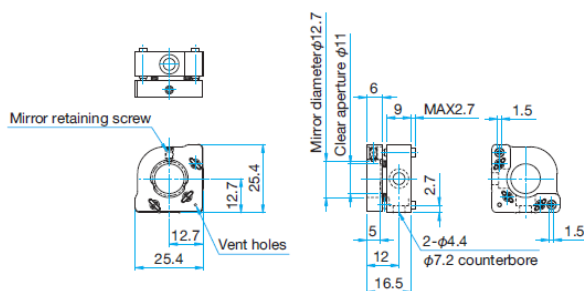

VMHG-25.4

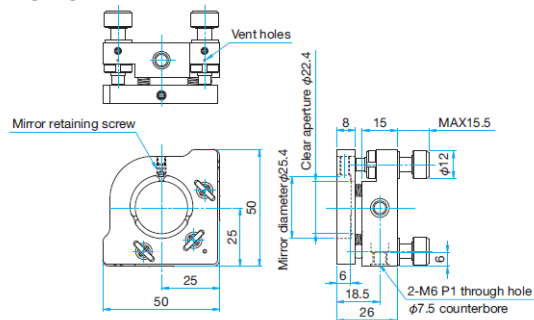

VMHG-30

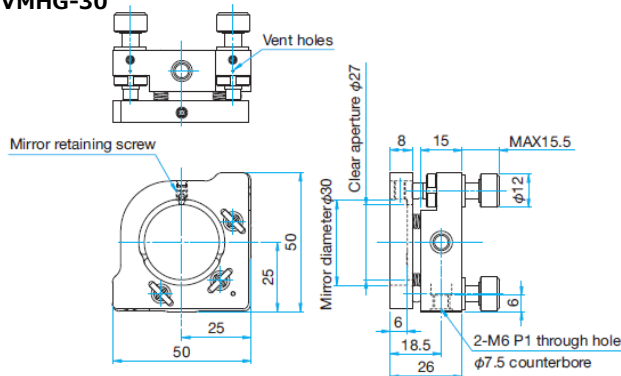

VMHG-50.8

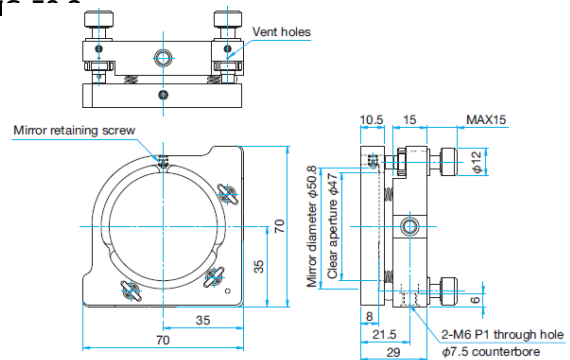

Specifications										Primary material: Steel (SUS316L)
										Finish: None
Part Number	Compatible Optics Diameter [mm]	Compatible Optics Thickness [mm]	Clear Aperture [mm]	Number of Adjustment Axes	Adjustment Range		Resolution		Weight [kg]	Compatible Mounting Screw Number
					Tilt [°]	Rotation [°]	Tilt [° /Rotation]	Rotation [° /Rotation]		
VMHG-12.7	$\phi 12.7$	3~7	$\phi 11$	2	± 3	± 3	about0.3	about0.3	0.032	VPCB-4-8 or VAGB-4-8
VMHG-25.4	$\phi 25.4$, $\phi 25$	3~10	$\phi 22.4$	2	± 3	± 3	about0.39	about0.39	0.21	VPCB-4-10 or VAGB-4-10
VMHG-30	$\phi 30$	3~10	$\phi 27$	2	± 3	± 3	about0.39	about0.39	0.19	VPCB-4-10 or VAGB-4-10
VMHG-50.8	$\phi 50$, $\phi 50.8$	3~10	$\phi 47$	2	± 2.5	± 2.5	about0.26	about0.26	0.35	VPCB-4-10 or VAGB-4-10