

Our highest performance vibration isolation system utilizes independent isolation mechanisms for the horizontal and vertical axes. This system achieves the highest performance and efficiency for the most demanding applications.

- This vibration isolator rapidly attenuates vibrations transmitted to mounted equipment and instruments, and is essential for equipment and instruments that are affected by vibration.
- The bench is lightweight and has excellent stiffness due to the steel honeycomb core.
- The top surface of the bench is made from a magnetic stainless steel with tapped holes (M6 25x25mm matrix).
- The manual leveling system does not require a continuous air supply. The isolators can be pressurized with just a hand air pump.

Exterior	 <p>OSDVIO</p>	
Natural Frequency	Vertical Direction	about 1.2 – 1.5Hz
	Horizontal Direction	about 1.5 – 1.7Hz
Vibration Isolation	Air Spring Isolations	
Damping	Air Damping by Orifice	
Honeycomb Material inside Bench	Plated steel honeycomb (0.25m foil, 3.2cm2 cell size)	
Bench Material	Upper Plate	4.0mm thickness 430 series ferro magnetic stainless steel plate, smooth sanded finish
	Lateral Side	2.0mm thickness carbon steel plate with damped wood composite, vinyl convert finish
	Lower Plate	4.0mm thickness carbon steel plate epoxy painted finish
Bench Top Surface	M6 tapped holes on 25x25mm matrix over the entire surface (leaving 37.5mm around the edges)	
Bench Top Surface Finish	Unpainted (smooth sanded finish)	
Surface Flatness	±0.1mm over 600mm square	
Hole/Core Sealing	Easy clean cylindrical cup (25mm deep)	

Guide

- ▶ We can produce sizes not listed in the catalog. Contact our Sales Division for more information.
- ▶ When installed in locations with no air source, use the silent air compressor (OSDAC-30) which can be used indoors.

Attention

- ▶ The vibration isolator will perform the best when the load on the table is evenly distributed.
- ▶ Freight is calculated separately. Use the carry-in route and installation environment question sheet.

Application Systems
Optics & Optical Coatings
Opto-Mechanics

Bases

Manual Stages
Actuators & Adjusters
Motorized Stages
Light Sources & Laser Safety
Index

Guide

Vibration Isolation Systems

Optical Tables

Darkrooms/ Dark Boxes

Optical Bases

Posts

Brackets

Adapters

Tools

Outline Drawing

OSDVIO series

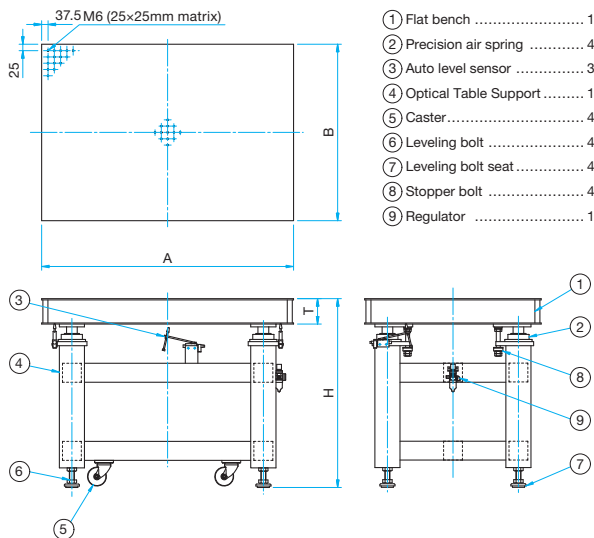

Application Systems

Optics & Optical Coatings

Opto-Mechanics

Bases

Manual Stages

Actuators & Adjusters

MotORIZED Stages

Light Sources & Laser Safety

Index

Guide

Vibration Isolation Systems

Optical Tables

Darkrooms/ Dark Boxes

Optical Bases

Posts

Brackets

Adapters

Tools

Specifications

Part Number	A x B [mm]	H [mm]	T [mm]	Load capacity [kg]	Weight [kg]
OSDVIO-I-0909M-100t(800H)	900x 900	800	100	300	154
OSDVIO-I-1007M-100t(800H)	1,000x 700	800	100	310	140
OSDVIO-I-1206M-100t(800H)	1,200x 600	800	100	310	141
OSDVIO-I-1207M-100t(800H)	1,200x 700	800	100	290	159
OSDVIO-I-1209M-100t(800H)	1,200x 900	800	100	260	190
OSDVIO-I-1506M-100t(800H)	1,500x 600	800	100	390	187
OSDVIO-I-1507M-100t(800H)	1,500x 700	800	100	370	207
OSDVIO-I-1509M-200t(800H)	1,500x 900	800	200	310	269
OSDVIO-I-1510M-200t(800H)	1,500x1,000	800	200	290	284
OSDVIO-I-1512M-200t(800H)	1,500x1,200	800	200	240	329
OSDVIO-I-1515M-200t(800H)	1,500x1,500	800	200	180	396
OSDVIO-I-1806M-200t(800H)	1,800x 600	800	200	340	234
OSDVIO-I-1807M-200t(800H)	1,800x 700	800	200	320	254
OSDVIO-I-1809M-200t(800H)	1,800x 900	800	200	270	306
OSDVIO-I-1812M-200t(800H)	1,800x1,200	800	200	190	387
OSDVIO-I-1815M-200t(800H)	1,800x1,500	800	200	420	468
OSDVIO-I-2010M-200t(800H)	2,000x1,000	800	200	520	362
OSDVIO-I-2012M-200t(800H)	2,000x1,200	800	200	460	421
OSDVIO-I-2015M-200t(800H)	2,000x1,500	800	200	380	510
OSDVIO-I-2409M-300t(800H)	2,400x 900	800	300	440	453
OSDVIO-I-2412M-300t(800H)	2,400x1,200	800	300	320	578
OSDVIO-I-2415M-300t(800H)	2,400x1,500	800	300	200	701
OSDVIO-I-3009M-300t(800H)	3,000x 900	800	300	350	585
OSDVIO-I-3010M-300t(800H)	3,000x1,000	800	300	300	634
OSDVIO-I-3012M-300t(800H)	3,000x1,200	800	300	200	739
OSDVIO-I-3015M-300t(800H)	3,000x1,500	800	300	450	896
OSDVIO-I-3612M-300t(800H)	3,600x1,200	800	300	480	864
OSDVIO-I-3615M-300t(800H)	3,600x1,500	800	300	309	1051