

ECR5050hs

Technical Specifications

Technology	
travel mechanism	inertial piezo drive
positioner type	rotator
Size and Dimensions	
footprint; height	50 x 50 ; 15 mm
max installation space	50 x 50 ; 15 mm
weight (aluminium version)	102 g
weight (stainless steel version)	214 g
Materials	
positioner body	Aluminum
actuator	PZT ceramics
connecting wires	copper, jacket: RT: silicon, HV/UHV: fiberglass
bearings	stainless steel
Load (@ ambient conditions)	
maximum load	20 N
maximum dynamic torque around axis	5 Ncm
Coarse Positioning Mode	
input voltage range	0 - 45 V
travel range (step mode)	360 °
maximum drive velocity @ 300 K	15 °/s
typical minimum step size @ 300 K	0.2 m°

Fine Positioning Mode	
fine positioning resolution	μ°
fine angular positioning range @ 300 K	15 m°
input DC voltage range @ 300 K	0 - 120 V
Accuracy of Movement	
repeatability of step sizes	typically 5 % over full range
typ. forward / backward step asymmetry	10 %
wobble	6 mrad
typical bearing clearance	0.15 mrad
Working Conditions	
mounting orientation	arbitrary
Connectors and Feedthroughs	
cable	50 cm cable with connector
connector type	14-pole connector
connector type (/HV, /UHV)	15-pin D-Sub connector
Options	
material options	/StSt, /Al
environmental options	/RT, /HV, /UHV
Versions	
/StSt/UHV Version	1012484
/StSt/HV Version	1012482
/Al/RT Version	1012481

AMC100
Piezo Positioning
Controller



Technical Drawings

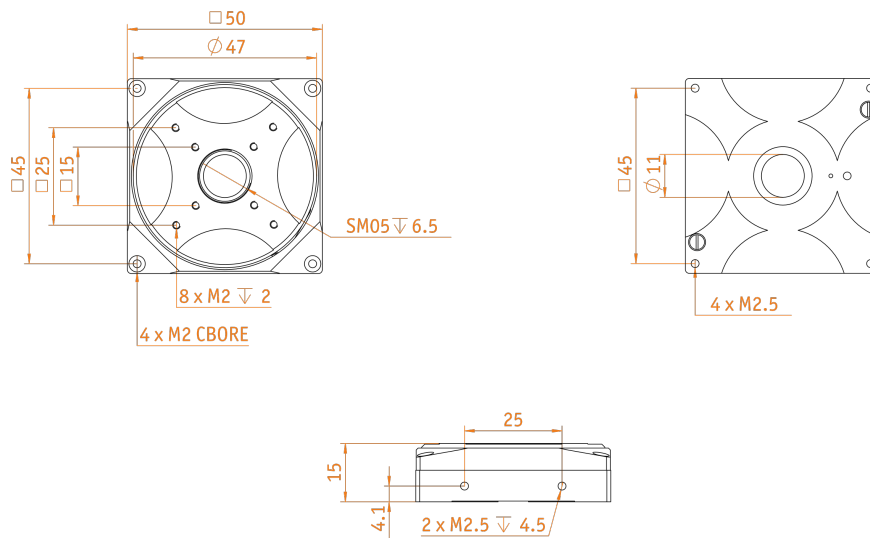

ECR5050hs/NUM(+)

Technical Specifications

Technology	
positioner type	rotator
Size and Dimensions	
footprint; height	50 x 50 ; 15 mm
max installation space	50 x 50 ; 15 mm
weight (aluminium version)	102 g
weight (stainless steel version)	214 g
Materials	
positioner body	Stainless Steel
actuator	PZT ceramics
connecting wires	copper, jacket: RT: silicon, HV/UHV: fiberglass
bearings	stainless steel
Load (@ ambient conditions)	
maximum load	20 N
maximum dynamic torque around axis	5 Ncm
Coarse Positioning Mode	
input voltage range	0 - 45 V
travel range (step mode)	360 °
maximum drive velocity @ 300 K	15 °/s
typical minimum step size @ 300 K	0.2 m°

Fine Positioning Mode	
fine positioning resolution	μ°
fine angular positioning range @ 300 K	m°
input DC voltage range @ 300 K	0 - 120 V
Accuracy of Movement	
typ. forward / backward step asymmetry	10 %
wobble	6 mrad
typical bearing clearance	0.15 mrad
Position Encoder	
readout mechanism	optoelectronic sensor
sensor power (when measuring)	50 mW
wavelength of illumination	870 nm
sensor resolution	0.01 m°
repeatability	1 m° (bidirectional)
absolute accuracy	< 0.01% of travel range
Working Conditions	
mounting orientation	arbitrary
Connectors and Feedthroughs	
cable	50 cm cable with connector
connector type	14-pole connector
electrical feedthrough solution	EVFT/HV, EVFT/UHV
Options	
material options	/StSt
encoder options	/NUM, /NUM+
environmental options	/HV, /UHV
Versions	
/StSt+/UHV Version	1012483
/StSt+/HV Version	1012478
/StSt/UHV Version	1012681
/StSt/HV Version	1012680



Technical Drawings

