

ECR4040/Al/RT

Art.Nr.: 1009634

Technical Specifications

Technology	
travel mechanism	inertial piezo drive
positioner type	rotator
Size and Dimensions	
footprint; height	40 x 40 ; 14.5 mm
max installation space	40 x 40 ; 14.5 mm
aperture	12.7 mm
weight	54 g
Materials	
positioner body	Aluminum
actuator	PZT ceramics
connecting wires	copper, jacket: RT: silicon, HV/UHV: fiberglass
bearings	stainless steel
Load (@ ambient conditions)	
maximum load	20 N
maximum dynamic torque around axis	2 Ncm
Coarse Positioning Mode	
input voltage range	0 - 60 V
travel range (step mode)	360 °
maximum drive velocity @ 300 K	10 °/s
typical minimum step size @ 300 K	0.2 m°

Fine Positioning Mode	
fine positioning resolution	μ°
fine angular positioning range @ 300 K	6 m°
input DC voltage range @ 300 K	0 - 100 V
Accuracy of Movement	
repeatability of step sizes	typically 5 % over full range
typ. forward / backward step asymmetry	10 %
Working Conditions	
mounting orientation	arbitrary
Connectors and Feedthroughs	
cable	50 cm cable with connector
connector type	14-pole connector



Technical Drawings

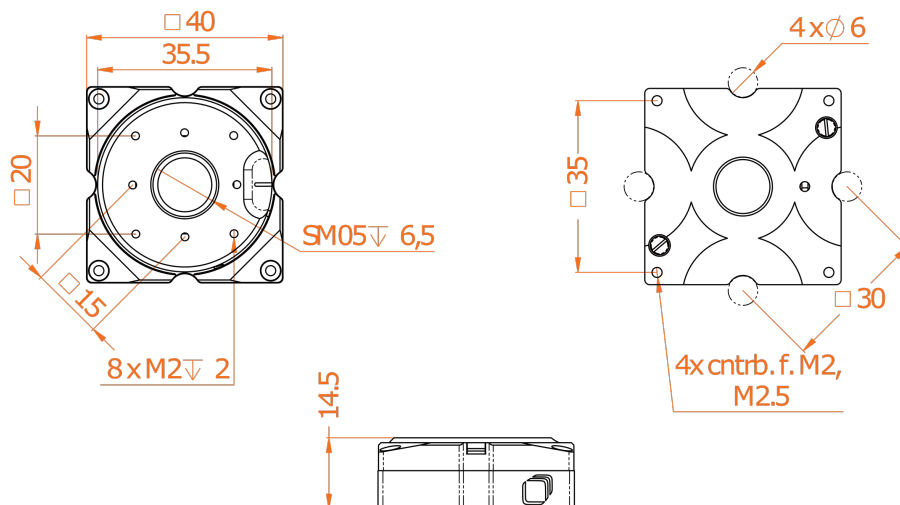

ECR4040/AL/NUM/RT

Art.Nr.: 1009637

Technical Specifications

Technology	
travel mechanism	inertial piezo drive
positioner type	rotator
Size and Dimensions	
footprint; height	40 x 40 ; 14.5 mm
max installation space	40 x 40 ; 14.5 mm
aperture	12.7 mm
weight	54 g
Materials	
positioner body	Aluminum
actuator	PZT ceramics
connecting wires	copper, jacket: RT: silicon, HV/UHV: fiberglass
bearings	stainless steel
Load (@ ambient conditions)	
maximum load	20 N
maximum dynamic torque around axis	2 Ncm
Coarse Positioning Mode	
input voltage range	0 - 60 V
travel range (step mode)	360 °
maximum drive velocity @ 300 K	10 °/s
typical minimum step size @ 300 K	0.2 m°

Fine Positioning Mode	
fine positioning resolution	μ°
fine angular positioning range @ 300 K	6 m°
input DC voltage range @ 300 K	0 - 100 V
Accuracy of Movement	
repeatability of step sizes	typically 5 % over full range
typ. forward / backward step asymmetry	10 %
Position Encoder	
readout mechanism	optoelectronic sensor
encoded travel range	360°
sensor power (when measuring)	300 mW
wavelength of illumination	870 nm
sensor resolution	0.04 m°
repeatability	4 m° (bidirectional)
absolute accuracy	< 0.01% of travel range
Working Conditions	
mounting orientation	arbitrary
Connectors and Feedthroughs	
cable	50 cm cable with connector
connector type	14-pole connector



Technical Drawings

