

# ECSz5050

## Technical Specifications

Technology	
travel mechanism	inertial piezo drive
positioner type	linear
Size and Dimensions	
footprint; height	50 x 50 ; 32 mm
max installation space	50 x 50 ; 40.5 mm
weight (aluminium version)	161 g
Materials	
positioner body	Aluminum
actuator	PZT ceramics
connecting wires	copper, jacket: RT: Teflon/PTFE
bearings	stainless steel
Load (@ ambient conditions)	
maximum load	8 N
maximum dynamic force along the axis	8 N
Coarse Positioning Mode	
travel range (step mode)	8 mm
maximum drive velocity @ 300 K	2 mm/s
typical minimum step size @ 300 K	30 nm

Fine Positioning Mode	
fine positioning resolution	sub-nm
fine linear positioning range @ 300 K	0.8 $\mu$ m
input DC voltage range @ 300 K	0 - 60 V
Accuracy of Movement	
repeatability of step sizes	typically 5 % over full range
typ. forward / backward step asymmetry	10 %
Working Conditions	
mounting orientation	arbitrary
Connectors and Feedthroughs	
cable	50 cm cable with connector
connector type	14-pole connector
Options	
material options	/AL
environmental options	/RT

AMC100  
Piezo Positioning  
Controller



## Technical Drawings

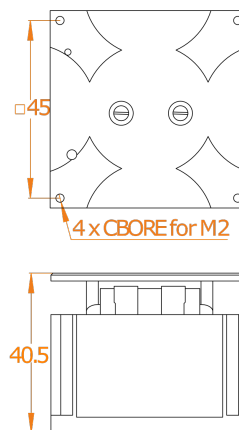
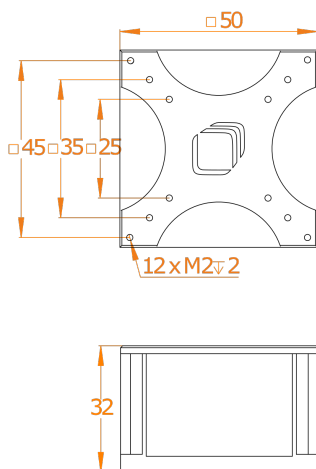

# ECSz5050/Al/NUM/RT

Art.Nr.: 1012096

## Technical Specifications

Technology	
travel mechanism	inertial piezo drive
positioner type	linear
Size and Dimensions	
footprint; height	50 x 50 ; 32 mm
max installation space	50 x 50 ; 40.5 mm
weight (aluminium version)	161 g
Materials	
positioner body	Aluminum
actuator	PZT ceramics
connecting wires	copper, jacket: RT: Teflon/PTFE
bearings	stainless steel
Load (@ ambient conditions)	
maximum load	8 N
maximum dynamic force along the axis	8 N
Coarse Positioning Mode	
travel range (step mode)	8 mm
maximum drive velocity @ 300 K	2 mm/s
typical minimum step size @ 300 K	30 nm

Fine Positioning Mode	
fine positioning resolution	sub-nm
fine linear positioning range @ 300 K	0.8 $\mu$ m
input DC voltage range @ 300 K	0 - 60 V
Accuracy of Movement	
repeatability of step sizes	typically 5 % over full range
typ. forward / backward step asymmetry	10 %
Position Encoder	
readout mechanism	optoelectronic sensor
encoded travel range	entire travel
sensor power (when measuring)	300 mW
wavelength of illumination	870 nm
sensor resolution	1 nm
repeatability	100 nm (bidirectional)
absolute accuracy	< 0.01% of travel range
Working Conditions	
mounting orientation	arbitrary
Connectors and Feedthroughs	
cable	50 cm cable with connector
connector type	14-pole connector

AMC100  
Piezo Positioning  
Controller



## Technical Drawings

