

ECSx3070

Technical Specifications

Technology	
travel mechanism	inertial piezo drive
positioner type	linear
Size and Dimensions	
footprint; height	30 x 70 ; 9.5 mm
max installation space	30 x 111.6 ; 9.5 mm
weight (aluminium version)	69 g
weight (stainless steel version)	129 g
Materials	
positioner body	Aluminum
actuator	PZT ceramics
connecting wires	copper, jacket: RT: silicon, HV/UHV: fiberglass
bearings	stainless steel
Load (@ ambient conditions)	
maximum load	210 N
maximum dynamic force along the axis	1 N
Coarse Positioning Mode	
input voltage range	0 - 60 V
travel range (step mode)	40 mm
maximum drive velocity @ 300 K	4.5 mm/s
typical minimum step size @ 300 K	50 nm

Fine Positioning Mode	
fine positioning resolution	sub-nm
fine linear positioning range @ 300 K	1.6 μ m
input DC voltage range @ 300 K	0 - 60 V
Accuracy of Movement	
repeatability of step sizes	typically 5 % over full range
typ. forward / backward step asymmetry	0.1
Working Conditions	
mounting orientation	arbitrary
Connectors and Feedthroughs	
cable	50 cm cable with connector
connector type	14-pole connector
High Load Option (/HL)	
/HL/RT - maximum dynamic force	5 N
Options	
material options	/StSt, /Al
high load option	/HL
environmental options	/RT, /HV, /UHV
Versions	
/StSt/UHV Version	1005693
/StSt/HV Version	1005681
/Al/RT Version	1005656
/Al/HL/RT Version	1008838

AMC100

Piezo Positioning Controller



Technical Drawings

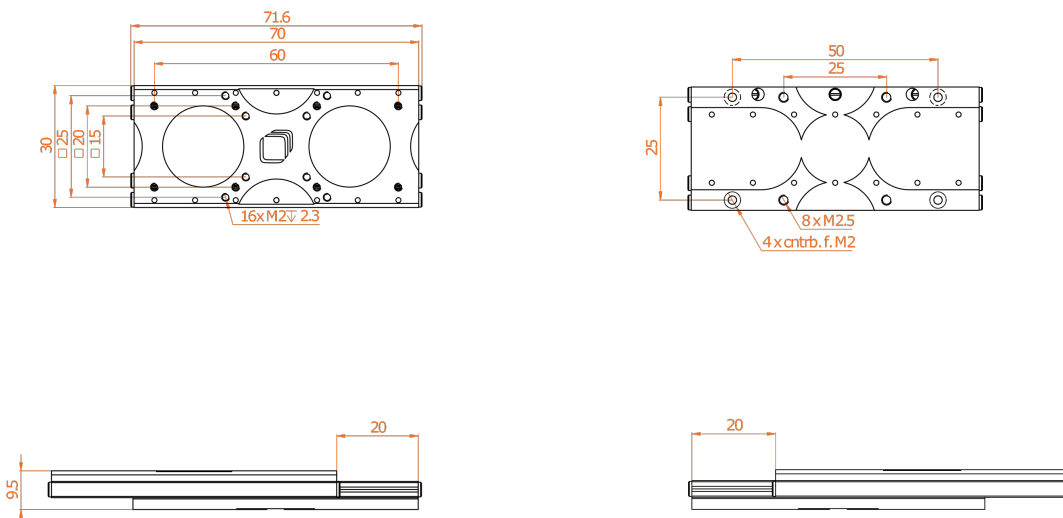

ECSx3070/NUM(+)

Technical Specifications

Technology	
travel mechanism	inertial piezo drive
positioner type	linear
Size and Dimensions	
footprint; height	30 x 70 ; 9.5 mm
max installation space	30 x 111.6 ; 9.5 mm
weight (aluminium version)	69 g
weight (stainless steel version)	129 g
Materials	
positioner body	Aluminum
actuator	PZT ceramics
connecting wires	copper, jacket: RT: silicon, HV/UHV: fiberglass
bearings	stainless steel
Load (@ ambient conditions)	
maximum load	210 N
maximum dynamic force along the axis	1 N
Coarse Positioning Mode	
input voltage range	0 - 60 V
travel range (step mode)	40 mm
maximum drive velocity @ 300 K	4.5 mm/s
typical minimum step size @ 300 K	50 nm

AMC100

Piezo Positioning
Controller



Fine Positioning Mode	
fine positioning resolution	sub-nm
fine linear positioning range @ 300 K	1.6 µm
input DC voltage range @ 300 K	0 - 60 V
Accuracy of Movement	
repeatability of step sizes	typically 5 % over full range
typ. forward / backward step asymmetry	0.1
Position Encoder	
readout mechanism	optoelectronic sensor
encoded travel range	entire travel
sensor power (when measuring)	300 mW
wavelength of illumination	870 nm
sensor resolution	1 nm
repeatability	50 nm (bidirectional)
absolute accuracy	< 0.01% of travel range
Working Conditions	
mounting orientation	arbitrary
Connectors and Feedthroughs	
cable	50 cm cable with connector
connector type	14-pole connector
High Load Option (/HL)	
/HL/RT - maximum dynamic force	5 N
Options	
material options	/StSt, /Al
encoder options	/NUM, /NUM+
high load option	/HL
environmental options	/RT, /HV, /UHV
Versions	
/StSt+/UHV Version	1011443
/StSt+/HV Version	1011442
/StSt/UHV Version	1005699
/StSt/HV Version	1005687
/Al/RT Version	1005663
/Al/HL/RT Version	1008847

Technical Drawings

