

High Performance Motorized Stages

Stage Size 60 × 60 mm / 100 × 80 mm / 120 × 120 mm

HPS

RoHS

CE

Motorized stages with ball screws and extended contact bearings offer mid to upper level performance at a low price.



- Ball screws improve durability compared to the existing lead screw driven TSDM series.
- Extended contact ball guides make it possible to offer a price lower than the crossed roller guide TAMM series.

Guide

- ▶ Please contact us when assembled into XYZ axis or mounted upside down on the ceiling or vertically on wall.
- ▶ Opposite model or various motor changes are optionally available.
[Reference](#) G030

Application Systems

Optics & Optical Coatings

Opto-Mechanics

Bases

Manual Stages

Actuators & Adjusters

Motorized Stages

Light Sources & Laser Safety

Index

Guide

Controllers/Drivers

Softwares

Stepping Motor

AC Servo Motor

Cables

Piezo

X Translation

Theta Rotation

Goniometer

Vacuum

Options

40 × 40 mm

60 × 60 mm

80 × 80 mm

85 × 85 mm

100 × 100 mm

120 × 120 mm

Others

Specifications

Part Number		HPS60-20X-M5	HPS80-50X-M5	HPS120-60X-M5	
Mechanical Specifications	Travel [mm]	20	50	60	
	Stage Size [mm]	60×60	100×80	120×120	
	Feed Screw	Ball screw diameter φ6mm, 1mm lead	Ball screw diameter φ6mm, 1mm lead	Ball screw diameter φ6mm, 1mm lead	
	Positioning Slide	Ball guide	Ball guide	Ball guide	
	Stage Material	Aluminum	Aluminum	Aluminum	
	Finish	Black anodized	Black anodized	Black anodized	
	Weight [kg]	0.6	1	1.5	
Accuracy Specifications	Resolution	(Full) [μm/pulse]	2	2	
		(Half) [μm/pulse]	1	1	
	MAX Speed [mm/sec]	10	10	10	
	Positioning Accuracy [μm]	15	25	25	
	Positional Repeatability [μm]	±1	±2	±2	
	Load Capacity [N]	49 (5kgf)	73.5 (7.5kgf)	98 (10kgf)	
	Moment Stiffness	Pitch [°/N·cm]	0.4	0.5	0.5
		Yaw [°/N·cm]	0.4	0.5	0.5
		Roll [°/N·cm]	0.3	0.2	0.2
	Lost Motion [μm]	1	2	2	
	Backlash [μm]	1	2	2	
	Parallelism [μm]	30	40	50	
	Running Parallelism [μm]	10	10	10	
	Pitch [°] / Yaw [°]	25/25	30/25	30/25	
Sensor	Sensor Part Number	Micro photo sensor: GP1S097HCZ(Sharp Corporation)			
	Limit Sensor	Equipped (NORMAL CLOSE)	Equipped (NORMAL CLOSE)	Equipped (NORMAL CLOSE)	
	Origin Sensor	Equipped (NORMAL OPEN)	Equipped (NORMAL OPEN)	Equipped (NORMAL OPEN)	
	Proximity Origin Sensor	None	None	None	

Motor / Sensor Specifications

Motor	Type	5-phase stepping motor 0.75A/phase (Oriental Motor Co., Ltd.)
	Motor Part Number	PK523HPB-C12 (□28mm)
	Step Angle	0.72°
Sensor	Power Voltage	DC5 - 24V ±10%
	Current Consumption	60mA or lower (20mA or lower per sensor)
	Control Output	NPN open collector output DC30V or lower, 50mA When load current is 16mA, the residual voltage is under 0.4V When load current is 50mA, the residual voltage is under 0.7V
	Output Logic	In the case of light shielded ,output transistor OFF (No conduction): Limit sensor In the case of light shielded ,output transistor ON (Conduction): Origin sensor

Compatible Driver / Controller

Control System	Compatible Driver	SG-5M, SG-5MA, MC-S0514ZU, SG-514MSC, MC-7514PCL
	Compatible Controller	GSC-01, GSC-02, SHOT-702, GIP-101, HSC-103, SHOT-302GS, SHOT-304GS, HIT-M-HIT-S, PGC-04-U



Outline Drawing

HPS60-20X-M5 Hexagon socket head cap screw M4x12...4 screws

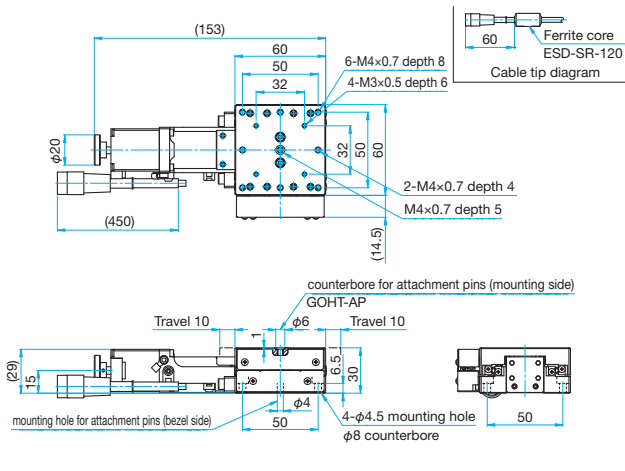

HPS80-50X-M5 Hexagon socket head cap screw M4x12...4 screws

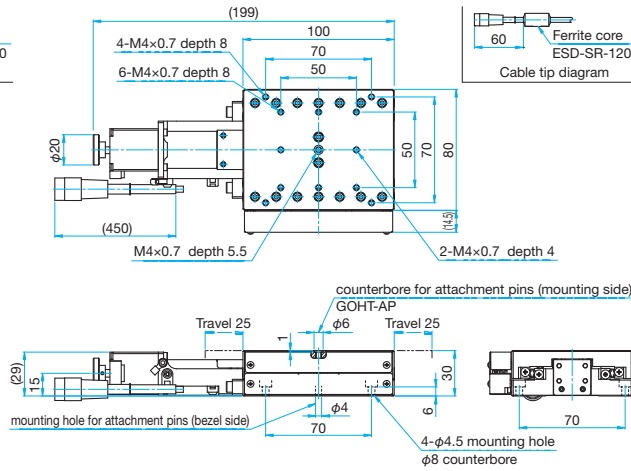

HPS120-60X-M5 Hexagon socket head cap screw M6x12...4 screws

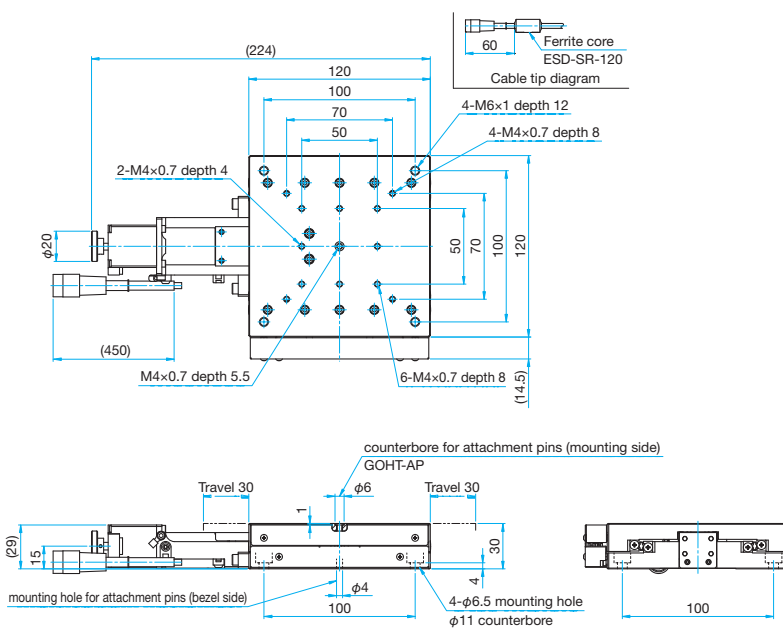

Connection Diagram

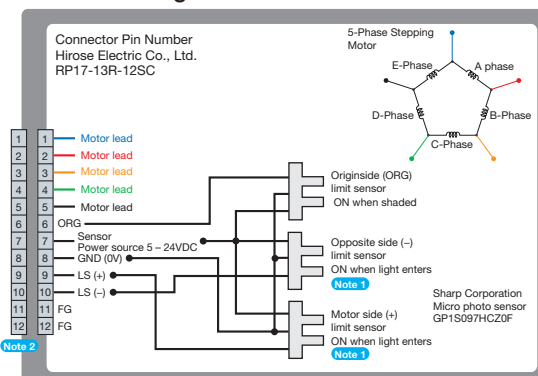

Note 1 The motor side limit sensor is the + direction limit sensor. Motorized stages are not fitted with proximity origin sensors.
Note 2 Compatible cable connector: Hirose Electric Co., Ltd. RP17-13PA-12PC/RP17-PC-122

Compatible Controllers / Drivers and Cables

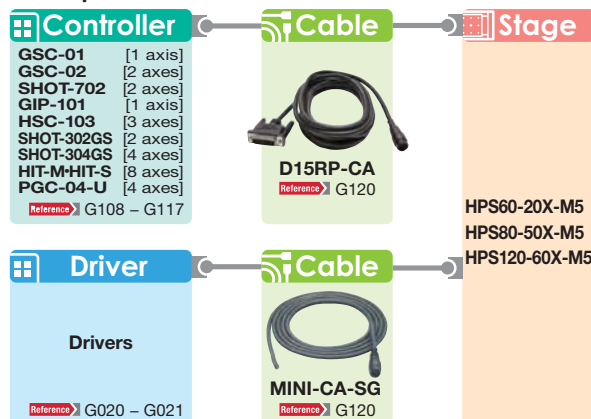

Application Systems

Optics & Optical Coatings

Opto-Mechanics

Bases

Manual Stages

Actuators & Adjusters

MotORIZED Stages

Light Sources & Laser Safety

Index

Guide

Controllers/Drivers

Softwares

Stepping Motor

AC Servo Motor

Cables

Piezo

X Translation

Theta Rotation

Goniometer

Vacuum

Options

40 x 40 mm

60 x 60 mm

80 x 80 mm

85 x 85 mm

100 x 100 mm

120 x 120 mm

Others

High Performance Motorized Stage Options

HPS Option

RoHS

Specification Method of Option Code

Option Code

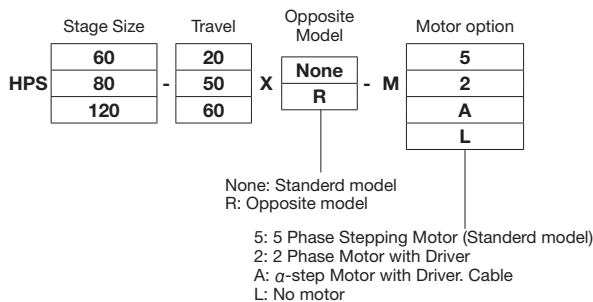

Example of Code Specification

HPS60-20X□-M□

Features of Options

2 Phase Motor with Driver	It can reduce the total cost because a driver is equipped. On the other hand, precision is inferior to 5 phase motors.
α Stepping Motor with Driver	Can be replaced with an α stepping motor with driver which can move fast. The motor also has built-in encoder.
No Motor	No Motor Provide a stage without motor because the customer mounts own motor. Note that mounting and adjustment of a motor requires specialized skills.



HPS120-60X-MA

Guide

- ▶ Please contact us when assembled into XYZ axis or use in reversion on the ceiling or vertical direction.
- ▶ Replacement with electromagnetic brakes or grease change is also available. Contact our Sales Division for more information.

Specifications (ex. HPS60-20X)

Part Number		☑ HPS60-20X-M2	☑ HPS60-20X-MA	HPS60-20X-ML	
Mechanical Specifications	Travel [mm]	20	20	20	
	Stage Size [mm]	60×60	60×60	60×60	
	Feed Screw	Ball screw diameter ϕ 6mm, 1mm lead	Ball screw diameter ϕ 6mm, 1mm lead	Ball screw diameter ϕ 6mm, 1mm lead	
	Positioning Slide	Ball guide	Ball guide	Ball guide	
	Stage Material	Aluminum	Aluminum	Aluminum	
	Finish	Black anodized	Black anodized	Black anodized	
	Weight [kg]	0.6	1	0.6	
Accuracy Specifications	Resolution	(Full) [μ m/pulse]	5	2 (500P/R)	—
		(Half) [μ m/pulse]	2.5	1 (1000P/R)	—
	MAX Speed [mm/sec]	20	40	—	
	Positioning Accuracy [μ m]	15	15	—	
	Positional Repeatability [μ m]	\pm 2	\pm 0.5	—	
	Load Capacity [N]	49 (5kgf)	49 (5kgf)	49 (5kgf)	
	Moment Stiffness	Pitch [$^{\circ}$ /N·cm]	0.4	0.4	0.4
		Yaw [$^{\circ}$ /N·cm]	0.4	0.4	0.4
		Roll [$^{\circ}$ /N·cm]	0.3	0.3	0.3
	Lost Motion [μ m]	1	1	—	
	Backlash [μ m]	1	1	1	
	Parallelism [μ m]	30	30	30	
	Running Parallelism [μ m]	10	10	10	
Pitch [$^{\circ}$] / Yaw [$^{\circ}$]	25/25	25/25	25-25		
Sensor	Sensor Part Number	Micro photo sensor: GP1S097HCZ (Sharp Corporation)	Micro photo sensor: GP1S097HCZ (Sharp Corporation)	Micro photo sensor: GP1S097HCZ (Sharp Corporation)	
	Limit Sensor	Equipped (NORMAL CLOSE)	Equipped (NORMAL CLOSE)	Equipped (NORMAL CLOSE)	
	Origin Sensor	Equipped (NORMAL OPEN)	Equipped (NORMAL OPEN)	Equipped (NORMAL OPEN)	
	Proximity Origin Sensor	None	None	None	

Motor / Sensor Specifications

	Type	2-phase stepping motor (Oriental Motor Co., Ltd.)	α STEP motor (Oriental Motor Co., Ltd.)	(No motor)
Motor	Motor Part Number	PKP223D15B (□28mm)	ARM26SBK (□28mm)	—
	Step Angle	1.8 $^{\circ}$	0.72 $^{\circ}$ (500P/R)	—
	Part Number	A8576-0415Y	ARD-K	—
Driver	Power input	DC24V \pm 10% 1A	DC24V \pm 10% 0.9A	—
	Power Voltage	DC5 - 24V \pm 10%		
Sensor	Current Consumption	60mA or lower (20mA or lower per sensor)		
	Control Output	NPN open collector output DC30V or lower, 50mA When load current is 16mA, the residual voltage is under 0.4V When load current is 50mA, the residual voltage is under 0.7V		
	Output Logic	In the case of light shielded ,output transistor OFF (No conduction): Limit sensor In the case of light shielded ,output transistor ON (Conduction): Origin sensor		

Application Systems

Optics & Optical Coatings

Opto-Mechanics

Bases

Manual Stages

Actuators & Adjusters

Motorized Stages

Light Sources & Laser Safety

Index

Guide

Controllers/Drivers

Softwares

Stepping Motor

AC Servo Motor

Cables

Piezo

X Translation

Theta Rotation

Goniometer

Vacuum

Options

40 x 40 mm

60 x 60 mm

80 x 80 mm

85 x 85 mm

100 x 100 mm

120 x 120 mm

Others



Outline Drawing

HPS60-20X-M2

Hexagon socket head cap screw M4x12...4 screws

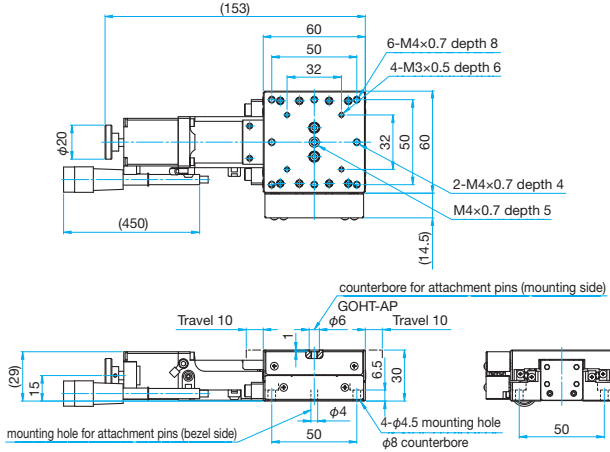

HPS60-20X-MA

Hexagon socket head cap screw M4x12...4 screws

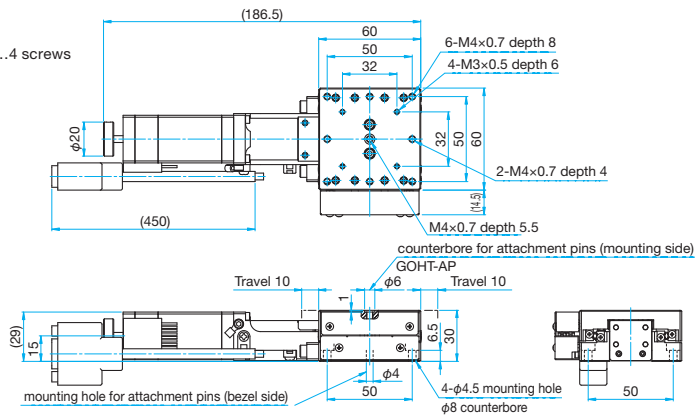

HPS60-20X-ML

Hexagon socket head cap screw M4x12...4 screws

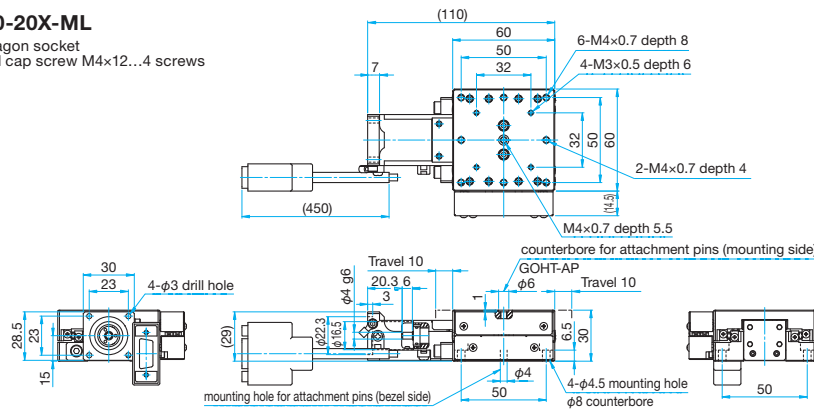

Connection Diagram

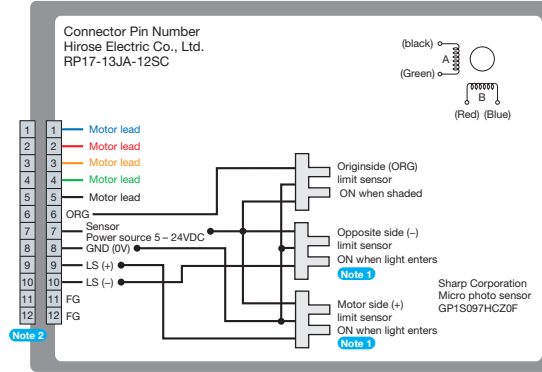

Connection Diagram

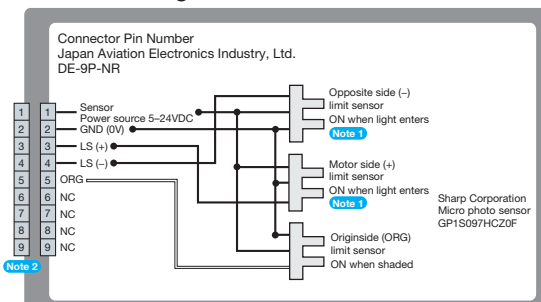

(Reference) Motor Comparison Table

Section	5 Phase Stepping Motor	2 Phase Stepping Motor	α STEP Motor
Positioning Accuracy	○	○	◎
Minute Feed Accuracy	○	○	○
Speed Stability	○	△	◎
Heat Generation (Continuous Operation)	○	△	◎
Max. Speed	○	○	◎
Rising Responsiveness	○	○	◎

*Rough guide for when the motors are mounted on our motorized stage.
 (◎ : goodness ○ : standard △ : inferior)

Application Systems

Optics & Optical Coatings

Opto-Mechanics

Bases

Manual Stages

Actuators & Adjusters

Motorized Stages

Light Sources & Laser Safety

Index

Guide

Controllers/Drivers

Softwares

Stepping Motor

AC Servo Motor

Cables

Piezo

X Translation

Theta Rotation

Goniometer

Vacuum

Options

40 x 40 mm

60 x 60 mm

80 x 80 mm

85 x 85 mm

100 x 100 mm

120 x 120 mm

Others