

XY Axis Steel Extended Contact Translation Stages

Stage Size 120 × 120 mm

TSD-1202

RoHS

Hardened steel linear translation stages with integrated bearing ways and a black chrome finish. Our “Extended Contact” technology yields superior stability, stiffness, accuracy, and durability. These XY stages are integrated and therefore have a lower profile vs. (2) single axis stages combined.

There are options for metric/inch, micrometer position and fine pitch screws.

- The $\phi 56$ mm aperture is maintained throughout the rated travel range.



Guide

- ▶ Choose from M4, M6, or, 1/4-20 Mounting and tapped holes..
- ▶ The suffix “UU” specifies 1/4-20 (Inch) and is able to mount directly onto vibration isolation systems or laboratory benches by using M6 or 1/4-20 screws.

Attention

- ▶ Micrometer brackets may extend above the top surface of some stages. Check drawings for more information.
- ▶ Note that based upon payload size, rated travel could be reduced.

Specifications

Part Number	METRIC	TSD-1202CH	TSD-1202SH	TSD-1202CH-M6	TSD-1202SH-M6
	INCH	—	—	TSD-1202CHUU	TSD-1202SHUU
(Opposite Model)	METRIC	—	TSD-1202SRH	—	TSD-1202SRH-M6
	INCH	—	—	—	TSD-1202SRHUU
Stage Size [mm]		120×120	120×120	120×120	120×120
Axes of Travel		XY axis			
Micrometer Position		Center	Side	Center	Side
Travel [mm]		±20	±20	±20	±20
Lead of Actuator [mm/rotation]		0.5	0.5	0.5	0.5
Micrometer Readable Resolution [mm]		0.01	0.01	0.01	0.01
Guide Method		Extended contact ball bearing guide			
Primary Material		Steel			
Finish		Super black chrome			
Load Capacity [N]		686 (70.0kgf)	686 (70.0kgf)	686 (70.0kgf)	686 (70.0kgf)
Travel Accuracy	Straightness [μ m]	0.5	0.5	0.5	0.5
	Pitch [$^{\circ}$]	25	25	25	25
	Yaw [$^{\circ}$]	15	15	15	15
Max. Moment Capacity	Pitch [N·m]	49.0	49.0	49.0	49.0
	Roll [N·m]	49.0	49.0	49.0	49.0
	Yaw [N·m]	27.0	27.0	27.0	27.0
Moment Stiffness	Pitch [$^{\circ}$ /N·cm]	0.05	0.05	0.05	0.05
	Roll [$^{\circ}$ /N·cm]	0.05	0.05	0.05	0.05
	Yaw [$^{\circ}$ /N·cm]	0.06	0.06	0.06	0.06
Parallelism [μ m]		50	50	50	50
Running Parallelism [μ m]		25	25	25	25
Orthogonality [μ m]		10	10	10	10
Weight [kg]		3.1	3.1	3.1	3.1

Application Systems

Optics & Optical Coatings

Opto-Mechanics

Bases

Manual Stages

Actuators & Adjusters

Motorized Stages

Light Sources & Laser Safety

Index

Guide

X Axis Stages

XY Axis Stages

Z Axis Stages

XZ Axis Stages

XYZ Axis Stages

Rotation Stages

Goniometer

Tilt Stages

Vacuum

Ball Bearing Guide

Crossed Roller

Dovetail

Lapping

V Groove Screw

Others

15 × 15 mm

25 × 25 mm

40 × 40 mm

60 × 60 mm

65 × 65 mm

80 × 80 mm

100 × 100 mm

120 × 120 mm

Others



Outline Drawing

TSD-1202CH Hexagonal socket head cap screw M4x8...4 screws

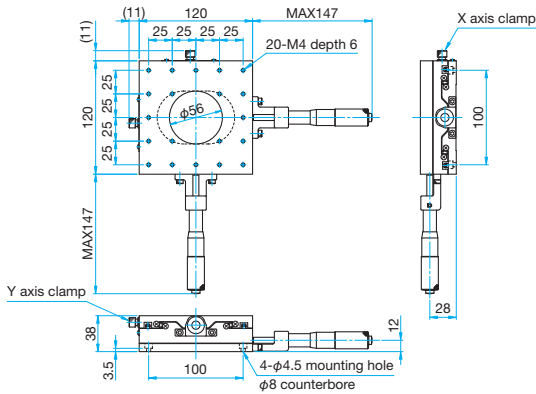

TSD-1202SH Hexagonal socket head cap screw M4x8...4 screws

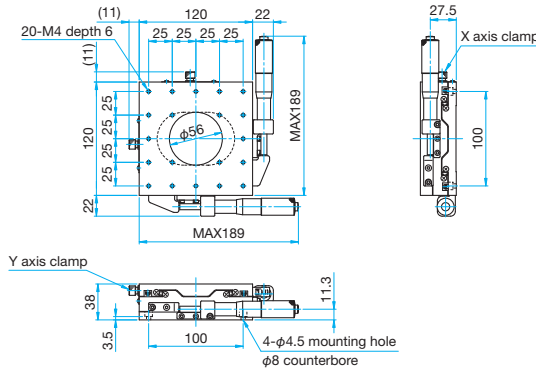

TSD-1202SRH Hexagonal socket head cap screw M4x8...4 screws

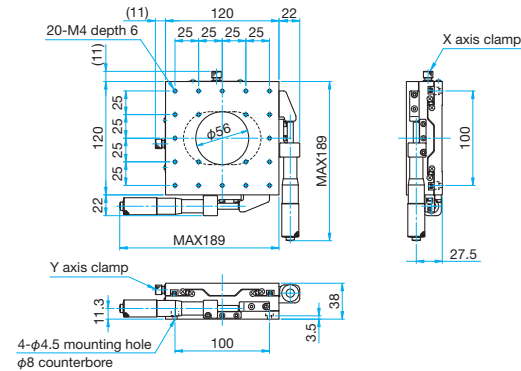

TSD-1202CH-M6/1202CHUU Hexagonal socket head cap screw M6x8...4 screws (M6)
Hexagonal socket head cap screw (stainless steel construction) 1/4-20UNCx5/16...4 screws (UU)

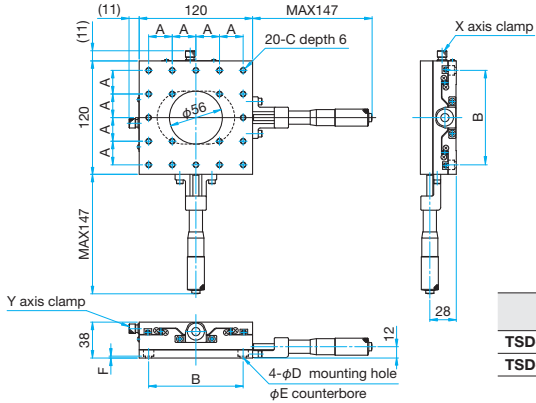

Part Number	A (mm)	B (mm)	C	D (mm)	E (mm)
TSD-1202CH-M6	25	100	M6 P1	6.5	11
TSD-1202CHUU	25.4	101.6	1/4-20UNC	7	12

TSD-1202SH-M6/1202SHUU Hexagonal socket head cap screw M6x8...4 screws (M6)
Hexagonal socket head cap screw (stainless steel construction) 1/4-20UNCx5/16...4 screws (UU)

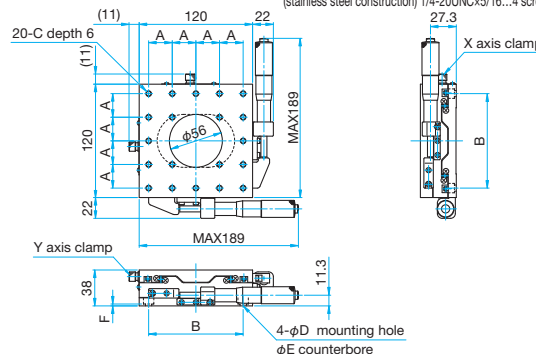

Part Number	A (mm)	B (mm)	C	D (mm)	E (mm)
TSD-1202SH-M6	25	100	M6 P1	6.5	11
TSD-1202SHUU	25.4	101.6	1/4-20UNC	7	12

TSD-1202SRH-M6/1202SRHUU Hexagonal socket head cap screw M6x8...4 screws (M6)
Hexagonal socket head cap screw (stainless steel construction) 1/4-20UNCx5/16...4 screws (UU)

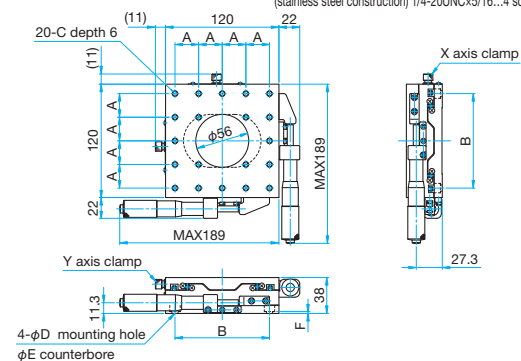

Part Number	A (mm)	B (mm)	C	D (mm)	E (mm)
TSD-1202SRH-M6	25	100	M6 P1	6.5	11
TSD-1202SRHUU	25.4	101.6	1/4-20UNC	7	12

Application Systems

Optics & Optical Coatings

Opto-Mechanics

Bases

Manual Stages

Actuators & Adjusters

Motoeized Stages

Light Sources & Laser Safety

Index

Guide

X Axis Stages

XY Axis Stages

Z Axis Stages

XZ Axis Stages

XYZ Axis Stages

Rotation Stages

Goniometer

Tilt Stages

Vacuum

Ball Bearing Guide

Crossed Roller

Dovetail

Lapping

V Groove Screw

Ohters

15 x 15 mm

25 x 25 mm

40 x 40 mm

60 x 60 mm

65 x 65 mm

80 x 80 mm

100 x 100 mm

120 x 120 mm

Others