

## Z axis precision stages that achieve extremely high parallelism using OptoSigma's unique adjustment technology.

- The top and bottom plates of the LJ model are made of steel (magnetic bases can be attached and detached), and the LJA models are made of aluminum.
- Pantograph mechanism provides a large adjustment range and high load capacity.
- Rotate the adjustment knob to adjust the height.
- Fine pitch lead screw enables good sensitivity.
- Stable locking is achieved with a split clamp system.



### Guide

- ▶ Height is adjustable using the spacer kits (LJS).  
Reference E120 Catalog Code W7056
- ▶ Use the platform (LJP) to mount larger samples.  
Reference E118 Catalog Code W7057
- ▶  $\alpha(\beta)$  axis tilt stage (AIS) in the same size as the labjack can be mounted.  
Reference E200 Catalog Code W7110



### Travel Variation Per Adjustment Handle Rotation

LJ/LJA-80133

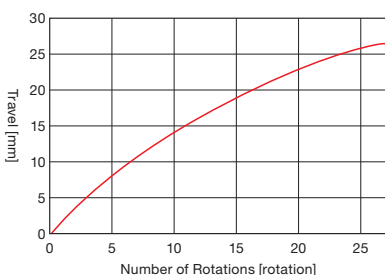

LJ/LJA-10163

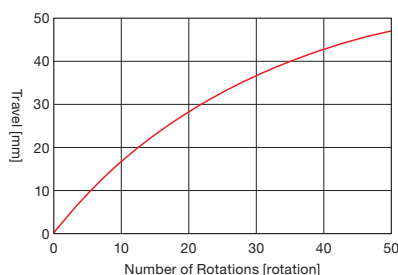

LJ/LJA-16223

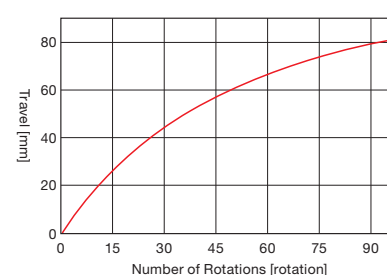

Application Systems

Optics &amp; Optical Coatings

Opto-Mechanics

Bases

Manual Stages

Actuators &amp; Adjusters

MotORIZED Stages

Light Sources &amp; Laser Safety

Index

Guide

X Axis Stages

XY Axis Stages

Z Axis Stages

XZ Axis Stages

XYZ Axis Stages

Rotation Stages

Goniometer

Tilt Stages

Vacuum

Ball Bearing Guide

Crossed Roller

Dovetail

Lapping

V Groove Screw

Others

15 × 15 mm

25 × 25 mm

40 × 40 mm

60 × 60 mm

65 × 65 mm

80 × 80 mm

100 × 100 mm

120 × 120 mm

Others

Specifications							
Part Number	LJ-80133	LJA-80133	LJ-10163	LJA-10163	LJ-16223	LJA-16223	
Stage Size [mm]	80×132	80×132	100×160	100×160	160×220	160×220	
Axes of Travel	Z axis						
Travel [mm]	22	22	40	40	70	70	
Primary Material	Steel	Aluminum	Steel	Aluminum	Steel	Aluminum	
Finish	Super black chrome	Black anodized	Super black chrome	Black anodized	Super black chrome	Black anodized	
Load Capacity [N]	196 (20.0kgf)	196 (20.0kgf)	245 (25.0kgf)	245 (25.0kgf)	294 (30.0kgf)	294 (30.0kgf)	
Max. Moment Capacity	Pitch [N·m]	29.4	29.4	38	38	49	49
	Roll [N·m]	2.9	2.9	4	4	6	6
Parallelism [ $\mu$ m]	100	100	100	100	100	100	
Weight [kg]	3.1	2.3	5.3	3.4	9.9	5.9	



Outline Drawing

LJ/LJA-80133

Hexagonal socket head cap screw  
M6x12...4 screws,  
One 5mm hex wrench

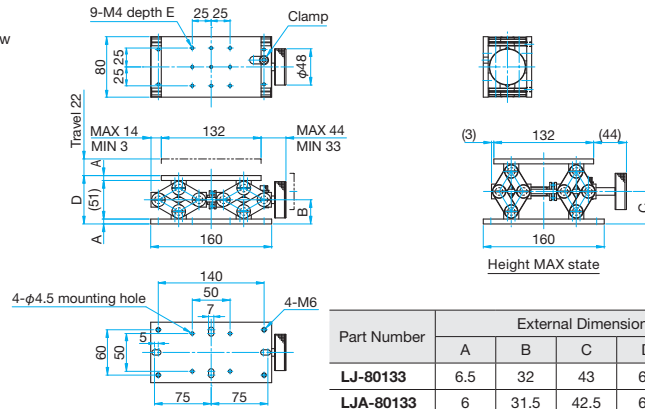

LJ/LJA-10163

Hexagonal socket head cap screw  
M6x16...4 screws,  
One 5mm hex wrench

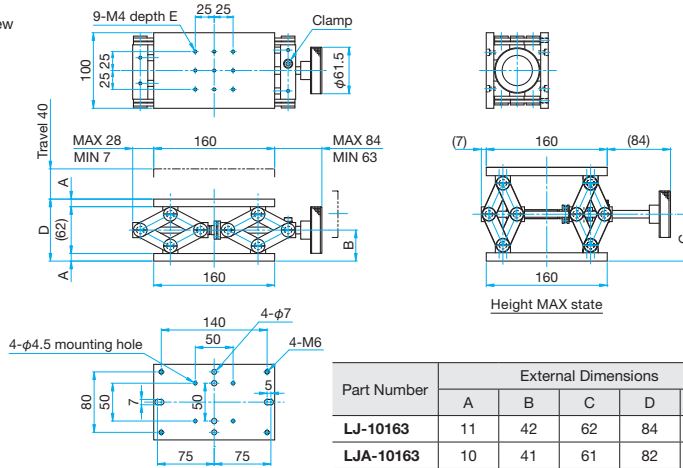

LJ/LJA-16223

Hexagonal socket head cap screw  
M6x16...4 screws,  
One 5mm hex wrench

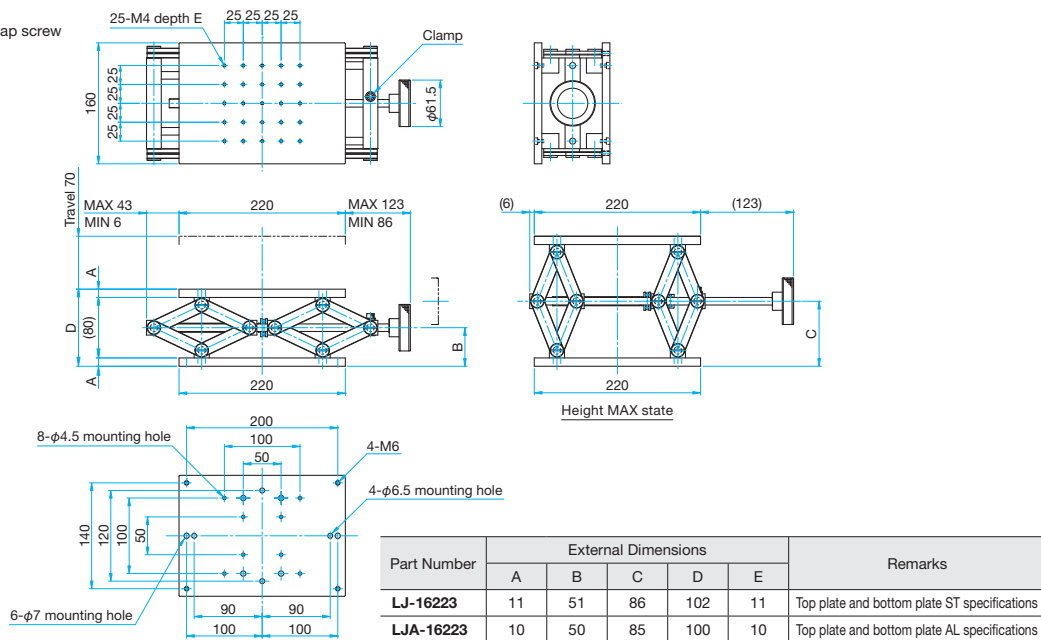

Application Systems

Optics & Optical Coatings

Opto-Mechanics

Bases

Manual Stages

Actuators & Adjusters

MotORIZED Stages

Light Sources & Laser Safety

Index

Guide

X Axis Stages

XY Axis Stages

Z Axis Stages

XZ Axis Stages

XYZ Axis Stages

Rotation Stages

Goniometer

Tilt Stages

Vacuum

Ball Bearing Guide

Crossed Roller

Dovetail

Lapping

V Groove Screw

Others

15 x 15 mm

25 x 25 mm

40 x 40 mm

60 x 60 mm

65 x 65 mm

80 x 80 mm

100 x 100 mm

120 x 120 mm

Others

## Z axis precision stages that achieve extremely high parallelism using OptoSigma's unique adjustment technology.

- The top and bottom plates of the LJ model are made of steel (magnetic bases can be attached and detached), and the LJA models are made of aluminum.
- Pantograph mechanism provides a large adjustment range and high load capacity.
- Rotate the adjustment knob to adjust the height.
- Fine pitch lead screw enables good sensitivity.
- Stable locking is achieved with a split clamp system.



### Guide

- ▶ Use the platform (LJP) to mount larger samples.

[Reference](#) E118 [Catalog Code](#) W7057

### Travel Variation Per Adjustment Handle Rotation

LJA-80133-M6/UU

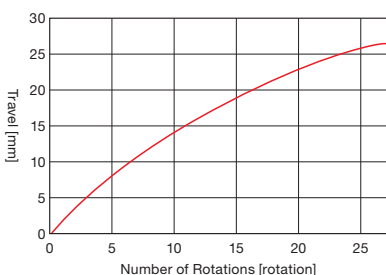

LJA-10163-M6/UU

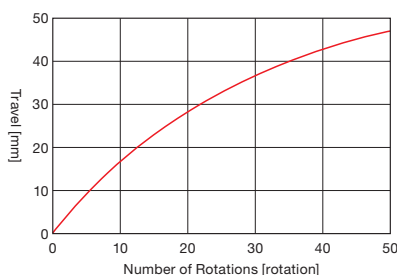

LJA-16223-M6/UU

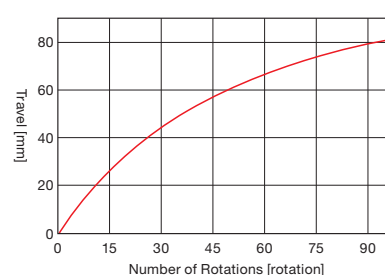

### Specifications

Part Number	METRIC	LJA-80133-M6	LJA-10163-M6	LJA-16223-M6
	INCH	LJA-80133UU	LJA-10163UU	LJA-16223UU
Stage Size [mm]		80x132	100x160	170x210
Axes of Travel		Z axis		
Travel [mm]		22	40	70
Primary Material		Aluminum		
Finish		Black anodized		
Load Capacity [N]		196 (20Kgf)	245 (25Kgf)	294 (30Kgf)
Max. Moment Capacity	Pitch [N·m]	29.4	38	49
	Roll [N·m]	2.9	4	6
Parallelism [μm]		100	100	100
Weight [kg]		2.3	3.4	5.9

Application Systems

Optics &amp; Optical Coatings

Opto-Mechanics

Bases

Manual Stages

Actuators &amp; Adjusters

Motorized Stages

Light Sources &amp; Laser Safety

Index

Guide

X Axis Stages

XY Axis Stages

Z Axis Stages

XZ Axis Stages

XYZ Axis Stages

Rotation Stages

Goniometer

Tilt Stages

Vacuum

Ball Bearing Guide

Crossed Roller

Dovetail

Lapping

V Groove Screw

Others

15 × 15 mm

25 × 25 mm

40 × 40 mm

60 × 60 mm

65 × 65 mm

80 × 80 mm

100 × 100 mm

120 × 120 mm

Others



Outline Drawing

**LJA-80133-M6/80133UU**

- Hexagonal socket head cap screw M6x12...4 screws, One 5mm hex wrench (M6)
- Hexagonal socket head cap screw 1/4-20UNCx1/2...4 screws, One 5mm hex wrench (UU)

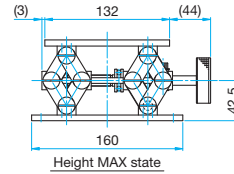
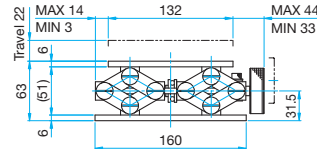
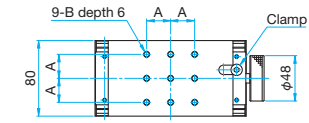

Part Number	A (mm)	B
LJA-80133-M6	25	M6 P1
LJA-80133UU	25.4	1/4-20UNC

**LJA-10163-M6/10163UU**

- Hexagonal socket head cap screw M6x12...4 screws, One 5mm hex wrench (M6)
- Hexagonal socket head cap screw 1/4-20UNCx1/2...4 screws, One 5mm hex wrench (UU)

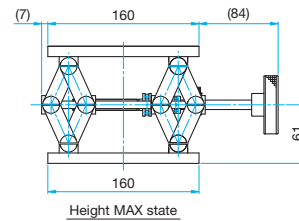
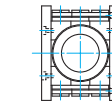
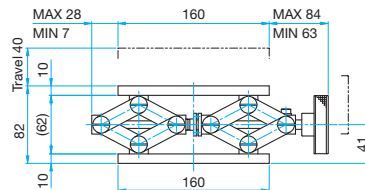
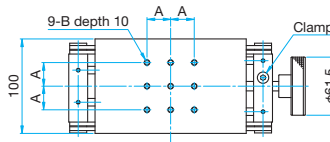

Part Number	A (mm)	B
LJA-10163-M6	25	M6 P1
LJA-10163UU	25.4	1/4-20UNC

**LJA-16223-M6/16223UU**

- Hexagonal socket head cap screw M6x12...4 screws, One 5mm hex wrench (M6)
- Hexagonal socket head cap screw 1/4-20UNCx1/2...4 screws, One 5mm hex wrench (UU)

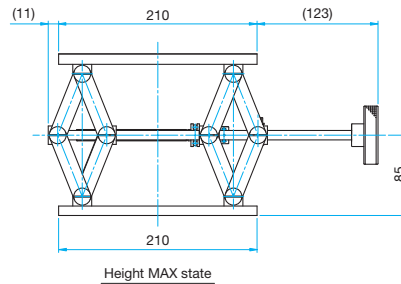
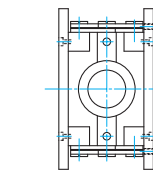
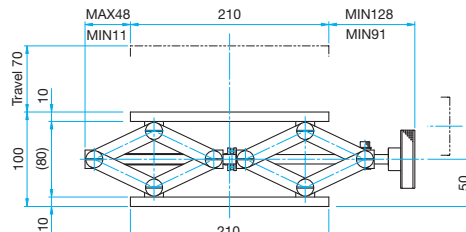
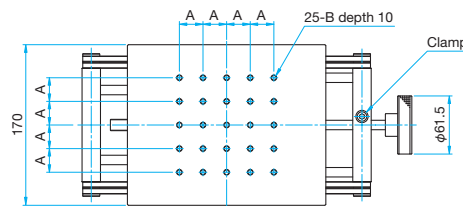

Part Number	A (mm)	B
LJA-16223-M6	25	M6 P1
LJA-16223UU	25.4	1/4-20UNC

Application Systems

Optics & Optical Coatings

Opto-Mechanics

Bases

Manual Stages

Actuators & Adjusters

MotORIZED Stages

Light Sources & Laser Safety

Index

Guide

X Axis Stages

XY Axis Stages

Z Axis Stages

XZ Axis Stages

XYZ Axis Stages

Rotation Stages

Goniometer

Tilt Stages

Vacuum

Ball Bearing Guide

Crossed Roller

Dovetail

Lapping

V Groove Screw

Others

15 x 15 mm

25 x 25 mm

40 x 40 mm

60 x 60 mm

65 x 65 mm

80 x 80 mm

100 x 100 mm

120 x 120 mm

Others