

# XZ Axis Stainless Steel Extended Contact Translation Stages (Vertical)

Stage Size 25 × 25 mm / 40 × 40 mm / 60 × 60 mm / 65 × 65 mm

TSDS-4L

RoHS

XZ axis Stainless Steel Linear Stages suitable for hard vacuum and clean room applications. Same design and performance as TSD stages.

Completely made of stainless steel for excellent corrosion resistance.

Both the stage and the stainless steel micrometer head are lubricated with a high grade vacuum grease (YVAC2).



## Guide

- ▶ The TSDS series stages are suitable for use in clean rooms or vacuum applications.  
[Reference](#) Vacuum measurement data E205z  
 Also ideal for use in airtight spaces that have to avoid outgassing.

Application Systems

Optics &amp; Optical Coatings

Opto-Mechanics

Bases

Manual Stages

Actuators &amp; Adjusters

Motorized Stages

Light Sources &amp; Laser Safety

Index

Guide

X Axis Stages

XY Axis Stages

Z Axis Stages

XZ Axis Stages

XYZ Axis Stages

Rotation Stages

Goniometer

Tilt Stages

Vacuum

Ball Bearing Guide

Crossed Roller

Dovetail

Lapping

V Groove Screw

Others

15 × 15 mm

25 × 25 mm

40 × 40 mm

60 × 60 mm

65 × 65 mm

80 × 80 mm

100 × 100 mm

120 × 120 mm

Others

## Specifications

Part Number	METRIC	TSDS-254CL	TSDS-254SL	TSDS-404CL	TSDS-404SL	TSDS-604CL	TSDS-604SL	TSDS-654CL-M6	TSDS-654SL-M6
	INCH	—	—	TSDS-404CLUU	TSDS-404SLUU	—	—	TSDS-654CLUU	TSDS-654SLUU
Stage Size [mm]		25×25	25×25	40×40	40×40	60×60	60×60	65×65	65×65
Axes of Travel		XZ axis							
Micrometer Position		Center	Side	Center	Side	Center	Side	Center	Side
Travel [mm]		X axis ±3 Z axis ±3	X axis ±3 Z axis ±3	X axis ±6.5 Z axis ±6.5	X axis ±6.5 Z axis ±6.5	X axis ±6.5 Z axis ±6.5	X axis ±6.5 Z axis ±6.5	X axis ±6.5 Z axis ±6.5	X axis ±6.5 Z axis ±6.5
Lead of Actuator [mm/rotation]		0.5	0.5	0.5	0.5	0.5	0.5	0.5	0.5
Micrometer Readable Resolution [mm]		0.01	0.01	0.01	0.01	0.01	0.01	0.01	0.01
Guide Method		Extended contact ball bearing guide							
Primary Material		Stainless steel							
Finish		None							
Load Capacity [N]		14.7 (1.5kgf)	14. (1.5kgf)	49 (5kgf)	49 (5kgf)	49 (5kgf)	49 (5kgf)	49 (5kgf)	49 (5kgf)
Travel Accuracy	Straightness [μm]	1	1	1	1	1	1	1	1
Max. Moment Capacity	Pitch [N·m]	2.2	2.2	3.9	3.9	8.0	8.0	8.0	8.0
	Roll [N·m]	2.1	2.1	3.9	3.9	8.0	8.0	8.0	8.0
Moment Stiffness	Pitch [°/N·cm]	5.1	5.1	0.96	0.96	0.45	0.45	0.45	0.45
Weight [kg]		0.17	0.17	0.5	0.5	1.3	1.3	1.45	1.45



**Outline Drawing**

**TSDS-254CL** Hexagon socket head cap screw (stainless steel construction) M2x4...4 screws

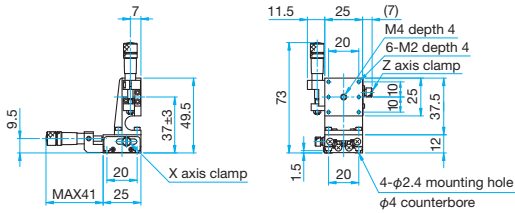

**TSDS-254SL** Hexagon socket head cap screw (stainless steel construction) M2x4...4 screws

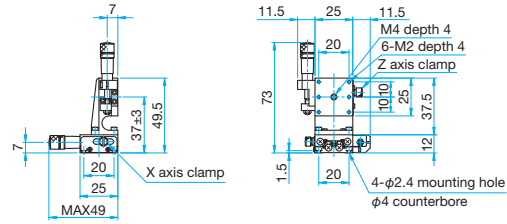

**TSDS-404CL/404CLUU**

Hexagon socket head cap screw (stainless steel construction) M3x6...4 screws, Spring washers  
Hexagon socket head cap screw (stainless steel construction) 6-32UNCx3/16...4 screws (UU)

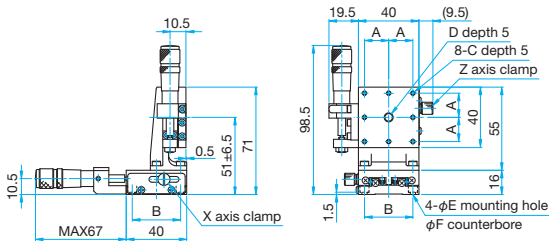

**TSDS-404SL/404SLUU**

Hexagon socket head cap screw (stainless steel construction) M3x6...4 screws, Spring washers  
Hexagon socket head cap screw (stainless steel construction) 6-32UNCx3/16...4 screws (UU)

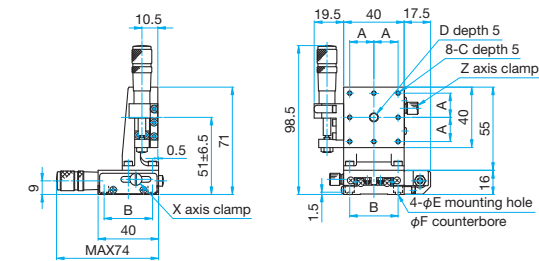

Part Number	A (mm)	B (mm)	C	D	E (mm)	F (mm)
TSDS-404CL	16	32	M3	M6 P1	3.5	6
TSDS-404CLUU	15.875	31.75	6-32UNC	1/4-20UNC	4	6.5

Part Number	A (mm)	B (mm)	C	D	E (mm)	F (mm)
TSDS-404SL	16	32	M3	M6 P1	3.5	6
TSDS-404SLUU	15.875	31.75	6-32UNC	1/4-20UNC	4	6.5

**TSDS-604CL** Hexagon socket head cap screw (stainless steel construction) M4x6...4 screws

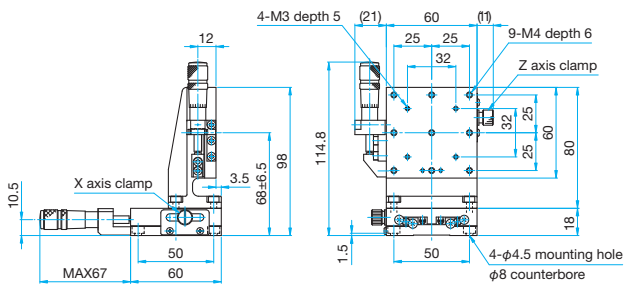

**TSDS-604SL** Hexagon socket head cap screw (stainless steel construction) M4x6...4 screws

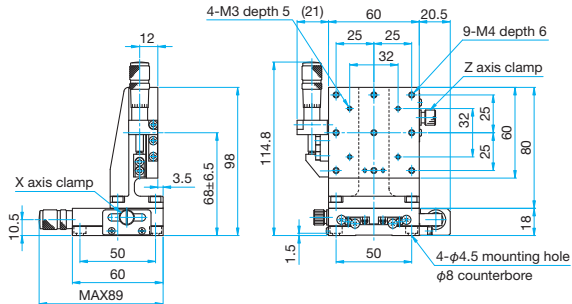

**TSDS-654CL-M6/654CLUU**

Hexagon socket head cap screw (stainless steel construction) M6x6...4 screws (M6)  
Hexagon socket head cap screw (stainless steel construction) 1/4-20UNCx1/4...4 screws (UU)

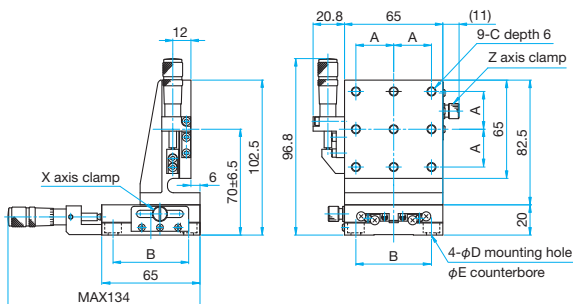

**TSDS-654SL-M6/654SLUU**

Hexagon socket head cap screw (stainless steel construction) M6x6...4 screws (M6)  
Hexagon socket head cap screw (stainless steel construction) 1/4-20UNCx1/4...4 screws (UU)

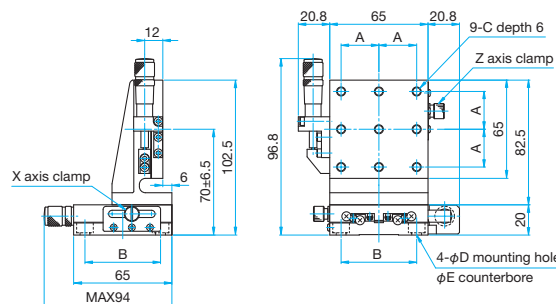

Part Number	A (mm)	B (mm)	C	D (mm)	E (mm)
TSDS-654CL-M6	25	50	M6 P1	6.5	11
TSDS-654CLUU	25.4	50.8	1/4-20UNC	7	12

Part Number	A (mm)	B (mm)	C	D (mm)	E (mm)
TSDS-654SL-M6	25	50	M6 P1	6.5	11
TSDS-654SLUU	25.4	50.8	1/4-20UNC	7	12

Application  
Systems

Optics &  
Optical  
Coatings

Opto-  
Mechanics

Bases

Manual  
Stages

Actuators &  
Adjusters

MotORIZED  
Stages

Light Sources &  
Laser Safety

Index

Guide

X Axis Stages

XY Axis Stages

Z Axis Stages

XZ Axis Stages

XYZ Axis Stages

Rotation Stages

Goniometer

Tilt Stages

Vacuum

Ball Bearing Guide

Crossed Roller

Dovetail

Lapping

V Groove Screw

Others

15 × 15 mm

25 × 25 mm

40 × 40 mm

60 × 60 mm

65 × 65 mm

80 × 80 mm

100 × 100 mm

120 × 120 mm

Others