

# XZ Axis Stainless Steel Extended Contact Translation Stages

Stage Size 25 × 25mm / 40 × 40 mm / 60 × 60 mm / 65 × 65 mm

TSDS-4

RoHS

XZ axis Stainless Steel Linear Stages suitable for hard vacuum and clean room applications. Same design and performance as TSD stages.

Completely made of stainless steel for excellent corrosion resistance.

Both the stage and the stainless steel micrometer head are lubricated with a high grade vacuum grease (YVAC2).



## Guide

- ▶ The TSDS series stages are suitable for use in clean rooms or vacuum applications.

[Reference](#) Vacuum measurement data E205

Also ideal for use in airtight spaces that have to avoid outgassing.

## Attention

- ▶ This translation stage type is not suitable for inverted use. In this condition, all load would be pulling against the spring.
- ▶ These stages use a pivot mechanism to transfer horizontal motion to vertical motion. This mechanism induces a small non-linearity between the distance the micrometer moves and the distance the stage platform moves. Contact our Sales Division for more information.
- ▶ Regarding 25 × 25mm and 40 × 40mm size stages, please do not apply heavy load toward the rotating ('yawing') direction, as it may damage the stage.

Specifications									
Part Number	METRIC	TSDS-254C	TSDS-254S	TSDS-404C	TSDS-404S	TSDS-604C	TSDS-604S	TSDS-654C-M6	TSDS-654S-M6
	INCH	—	—	TSDS-404CUU	TSDS-404SUU	—	—	TSDS-654CUU	TSDS-654SUU
Stage Size [mm]		25×25	25×25	40×40	40×40	60×60	60×60	65×65	65×65
Axes of Travel		XZ axis							
Micrometer Position		Center	Side	Center	Side	Center	Side	Center	Side
Travel [mm]		X axis ±3 Z axis ±3	X axis ±3 Z axis ±3	X axis ±6.5 Z axis ±3	X axis ±6.5 Z axis ±3	X axis ±6.5 Z axis ±5	X axis ±6.5 Z axis ±5	X axis ±6.5 Z axis ±5	X axis ±6.5 Z axis ±5
Lead of Actuator [mm/rotation]		0.5	0.5	0.5	0.5	0.5	0.5	0.5	0.5
Micrometer Readable Resolution [mm]		0.01	0.01	0.01	0.01	0.01	0.01	0.01	0.01
Guide Method		Extended contact ball bearing guide							
Primary Material		Stainless steel							
Finish		None							
Load Capacity [N]		29.4 (3.0kgf)	29.4 (3.0kgf)	88.3 (9.0kgf)	88.3 (9.0kgf)	147 (15.0kgf)	147 (15.0kgf)	147 (15.0kgf)	147 (15.0kgf)
Travel Accuracy	Straightness [μm]	5	5	2.5	2.5	2.5	2.5	2.5	2.5
Max. Moment Capacity	Pitch [N·m]	1.0	1.0	3.9	3.9	6.9	6.9	6.9	6.9
	Roll [N·m]	1.0	1.0	3.9	3.9	6.9	6.9	6.9	6.9
Moment Stiffness	Pitch [°/N·cm]	8.95	8.95	2.2	2.2	0.75	0.75	0.75	0.75
	Roll [°/N·cm]	8.75	8.75	2.15	2.15	0.75	0.75	0.75	0.75
Parallelism [μm]		110	110	110	110	110	110	110	110
Weight [kg]		0.17	0.17	0.45	0.45	1.5	1.5	1.65	1.65

Application Systems

Optics &amp; Optical Coatings

Opto-Mechanics

Bases

Manual Stages

Actuators &amp; Adjusters

Motorized Stages

Light Sources &amp; Laser Safety

Index

Guide

X Axis Stages

XY Axis Stages

Z Axis Stages

XZ Axis Stages

XYZ Axis Stages

Rotation Stages

Goniometer

Tilt Stages

Vacuum

Ball Bearing Guide

Crossed Roller

Dovetail

Lapping

V Groove Screw

Others

15 × 15 mm

25 × 25 mm

40 × 40 mm

60 × 60 mm

65 × 65 mm

80 × 80 mm

100 × 100 mm

120 × 120 mm

Others



**Outline Drawing**

**TSDS-254C** Hexagon socket head cap screw (stainless steel construction) M2x4...4 screws

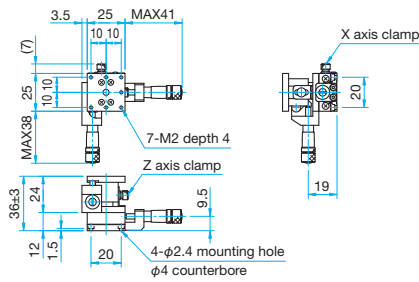

**TSDS-254S** Hexagon socket head cap screw (stainless steel construction) M2x4...4 screws

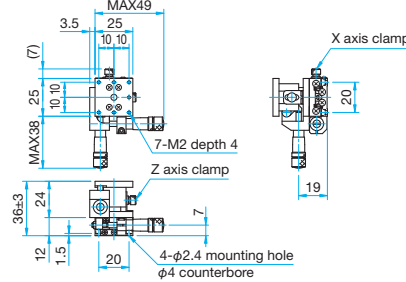

**TSDS-404C/404CUU**

Hexagon socket head cap screw (stainless steel construction) M3x6...4 screws, Spring washers  
Hexagon socket head cap screw (stainless steel construction) 6-32UNCx3/16...4 screws (UU)

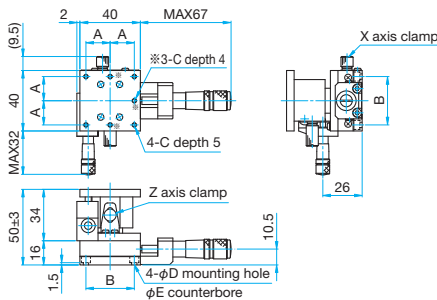

**TSDS-404S/404SUU**

Hexagon socket head cap screw (stainless steel construction) M3x6...4 screws, Spring washers  
Hexagon socket head cap screw (stainless steel construction) 6-32UNCx3/16...4 screws (UU)

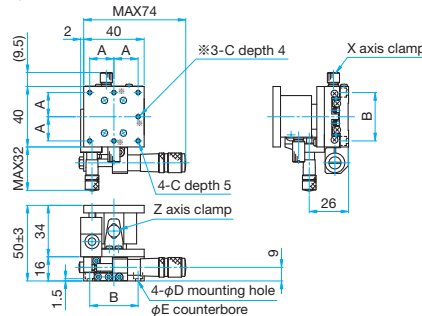

Part Number	A (mm)	B (mm)	C	D (mm)	E (mm)
TSDS-404C	16	32	M3	3.5	6
TSDS-404CUU	15.875	31.75	6-32UNC	4	6.5

Part Number	A (mm)	B (mm)	C	D (mm)	E (mm)
TSDS-404S	16	32	M3	3.5	6
TSDS-404SUU	15.875	31.75	6-32UNC	4	6.5

**TSDS-604C** Hexagon socket head cap screw (stainless steel construction) M4x6...4 screws

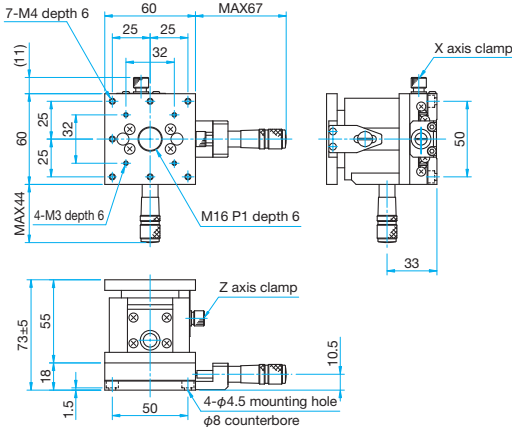

**TSDS-604S** Hexagon socket head cap screw (stainless steel construction) M4x6...4 screws

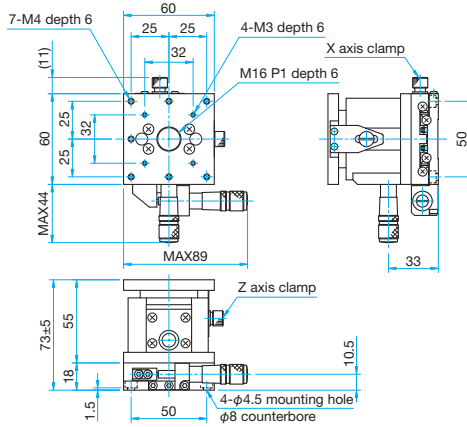

**TSDS-654C-M6/654CUU**

Hexagon socket head cap screw (stainless steel construction) M6x6...4 screws (M6)  
Hexagon socket head cap screw (stainless steel construction) 1/4-20UNCx1/4...4 screws (UU)

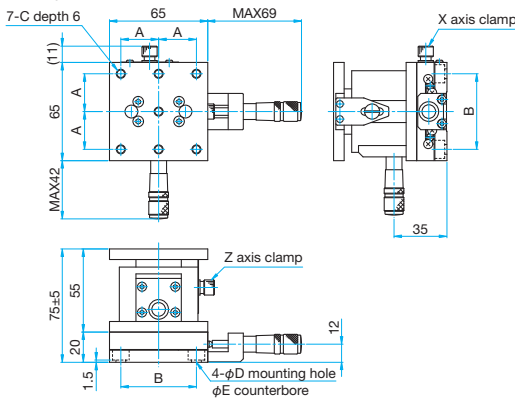

**TSDS-654S-M6/654SUU**

Hexagon socket head cap screw (stainless steel construction) M6x6...4 screws (M6)  
Hexagon socket head cap screw (stainless steel construction) 1/4-20UNCx1/4...4 screws (UU)

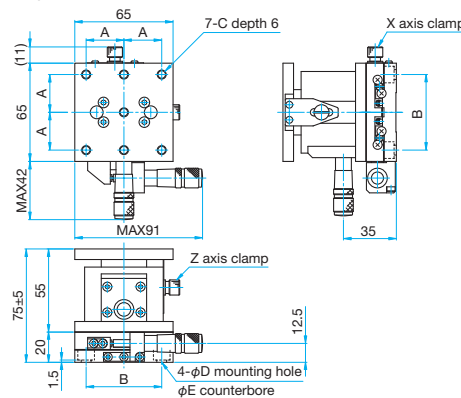

Part Number	A (mm)	B (mm)	C	D (mm)	E (mm)
TSDS-654C-M6	25	50	M6 P1	6.5	11
TSDS-654CUU	25.4	50.8	1/4-20UNC	7	12

Part Number	A (mm)	B (mm)	C	D (mm)	E (mm)
TSDS-654S-M6	25	50	M6 P1	6.5	11
TSDS-654SUU	25.4	50.8	1/4-20UNC	7	12

Application Systems

Optics & Optical Coatings

Opto-Mechanics

Bases

Manual Stages

Actuators & Adjusters

MotORIZED Stages

Light Sources & Laser Safety

Index

Guide

X Axis Stages

XY Axis Stages

Z Axis Stages

XZ Axis Stages

XYZ Axis Stages

Rotation Stages

Goniometer

Tilt Stages

Vacuum

Ball Bearing Guide

Crossed Roller

Dovetail

Lapping

V Groove Screw

Others

15 x 15 mm

25 x 25 mm

40 x 40 mm

60 x 60 mm

65 x 65 mm

80 x 80 mm

100 x 100 mm

120 x 120 mm

Others