

XYZ Axis Steel Extended Contact Translation Stages (Vertical)

TSD-255L Stage Size 25 x 25 mm

TSD-405L Stage Size 40 x 40 mm

RoHS

RoHS

This XYZ assembly incorporates an integrated (XY) axis steel linear stage and a (Z) axis steel stage with an integrated vertical bracket.

There are options for micrometer position and fine pitch screws.



Guide

- ▶ Vacuum-compatible stainless steel stages (TSDS-255*L/405*L) are also available. [Reference](#) E218 [Catalog Code](#) W7080

Specifications					
Part Number	METRIC	TSD-255CL	TSD-255SL	TSD-405CL	TSD-405SL
	INCH	—	—	TSD-405CLUU	TSD-405SLUU
(Opposite Model)	METRIC	—	TSD-255SRL	—	TSD-405SRL
	INCH	—	—	—	TSD-405SRLUU
Stage Size [mm]		25x25	25x25	40x40	40x40
Axes of Travel		XYZ axis			
Micrometer Position		Center	Side	Center	Side
Travel [mm]		XY axis ±3 Z axis ±3	XY axis ±3 Z axis ±3	XY axis ±6.5 Z axis ±6.5	XY axis ±6.5 Z axis ±6.5
Lead of Actuator [mm/rotation]		0.5	0.5	0.5	0.5
Micrometer Readable Resolution [mm]		0.01	0.01	0.01	0.01
Guide Method		Extended contact ball bearing guide			
Primary Material		Steel			
Finish		Super black chrome			
Load Capacity [N]		14.7 (1.5kgf)	14.7 (1.5kgf)	49 (5.0kgf)	49 (5.0kgf)
Travel Accuracy	Straightness [μm]	1	1	1	1
Max. Moment Capacity	Pitch [N·m]	2.2	2.2	5.0	5.0
	Roll [N·m]	2.1	2.1	5.0	5.0
Moment Stiffness	Pitch ["/N·cm]	6.7	6.7	1.1	1.1
	Options	FP	FP	FP	FP
Weight [kg]		0.2	0.2	0.6	0.6

Option for □25mm

Option Code	Compatible product		Lead of Actuator [mm/rotation]	Micrometer Readable Resolution [mm]	Reference
	Products Name	Part Number			
FP	Fine-pitch Screw Adjusters	FPSA-42525	0.25	—	E008

Option for □40mm

Option Code	Compatible product		Lead of Actuator [mm/rotation]	Micrometer Readable Resolution [mm]	Reference
	Products Name	Part Number			
FP	Fine-pitch Screw Adjusters	FPSA-62540	0.25	—	E008

* Please add an option code as the part number suffix to specify various optional specifications.

* The FP type requires a hex wrench or the optional hex wrench with knob (KCL) for driving operation. [Reference](#) F010 [Catalog Code](#) W8008

Application Systems

Optics & Optical Coatings

Opto-Mechanics

Bases

Manual Stages

Actuators & Adjusters

Motorized Stages

Light Sources & Laser Safety

Index

Guide

X Axis Stages

XY Axis Stages

Z Axis Stages

XZ Axis Stages

XYZ Axis Stages

Rotation Stages

Goniometer

Tilt Stages

Vacuum

Ball Bearing Guide

Crossed Roller

Dovetail

Lapping

V Groove Screw

Others

15 x 15 mm

25 x 25 mm

40 x 40 mm

60 x 60 mm

65 x 65 mm

80 x 80 mm

100 x 100 mm

120 x 120 mm

Others



Outline Drawing

TSD-255CL Hexagonal socket head cap screw M2x4...4 screws

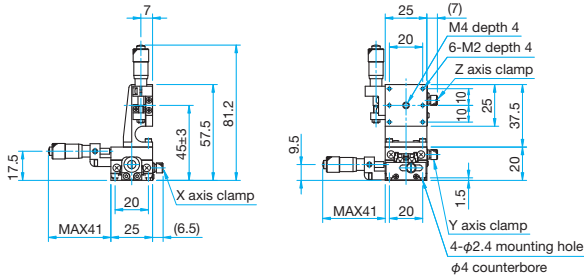

TSD-255SL Hexagonal socket head cap screw M2x4...4 screws

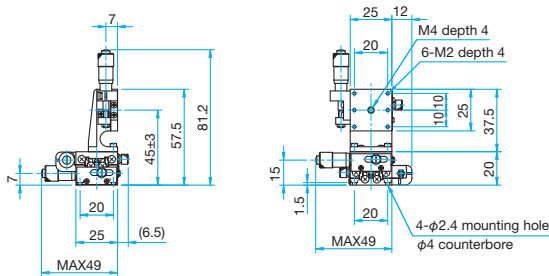

TSD-255SRL Hexagonal socket head cap screw M2x4...4 screws

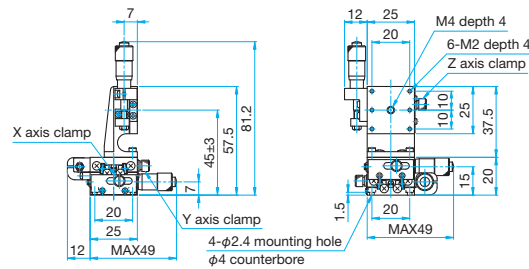

TSD-405CL/405CLUU Hexagonal socket head cap screw M3x6...4 screws, Spring washers
Hexagonal socket head cap screw 6-32UNCx3/6...4 screws (UU)

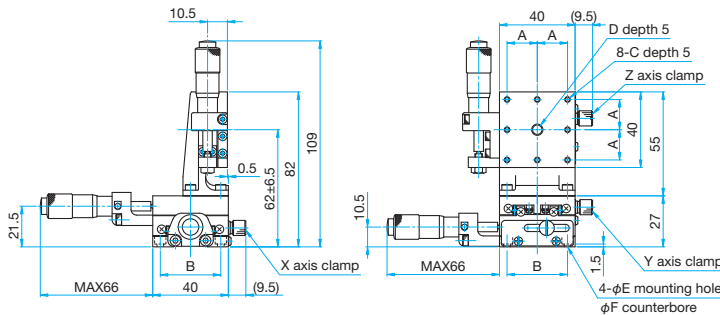

Part Number	A (mm)	B (mm)	C	D	E (mm)	F (mm)
TSD-405CL	16	32	M3	M6 P1	3.5	6
TSD-405CLUU	15.875	31.75	6-32UNC	1/4-20UNC	4	6.5

TSD-405SL/405SLUU Hexagonal socket head cap screw M3x6...4 screws, Spring washers
Hexagonal socket head cap screw 6-32UNCx3/6...4 screws (UU)

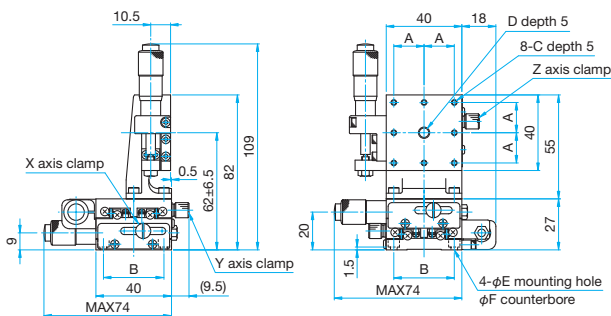

Part Number	A (mm)	B (mm)	C	D	E (mm)	F (mm)
TSD-405SL	16	32	M3	M6 P1	3.5	6
TSD-405SLUU	15.875	31.75	6-32UNC	1/4-20UNC	4	6.5

TSD-405SRL/405SRLUU Hexagonal socket head cap screw M3x6...4 screws, Spring washers
Hexagonal socket head cap screw 6-32UNCx3/6...4 screws (UU)

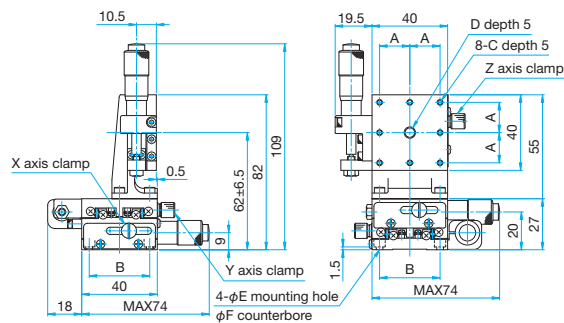

Part Number	A (mm)	B (mm)	C	D	E (mm)	F (mm)
TSD-405SRL	16	32	M3	M6 P1	3.5	6
TSD-405SRLUU	15.875	31.75	6-32UNC	1/4-20UNC	4	6.5

Application Systems

Optics & Optical Coatings

Opto-Mechanics

Bases

Manual Stages

Actuators & Adjusters

MotORIZED Stages

Light Sources & Laser Safety

Index

Guide

X Axis Stages

XY Axis Stages

Z Axis Stages

XZ Axis Stages

XYZ Axis Stages

Rotation Stages

Goniometer

Tilt Stages

Vacuum

Ball Bearing Guide

Crossed Roller

Dovetail

Lapping

V Groove Screw

Others

15 x 15 mm

25 x 25 mm

40 x 40 mm

60 x 60 mm

65 x 65 mm

80 x 80 mm

100 x 100 mm

120 x 120 mm

Others

XYZ Axis Steel Extended Contact Translation Stages (Vertical)

TSD-605L Stage Size 60 x 60 mm

RoHS

TSD-655L Stage Size 65 x 65 mm

RoHS

This XYZ assembly incorporates an integrated (XY) axis steel linear stage and a (Z) axis steel stage with an integrated vertical bracket.

There are options for micrometer position and fine pitch screws.



Guide

► Vacuum-compatible stainless steel stages (TSDS-605*L/655*L) are also available. [Reference](#) E218 [Catalog Code](#) W7080

Application Systems

Optics & Optical Coatings

Opto-Mechanics

Bases

Manual Stages

Actuators & Adjusters

Motorized Stages

Light Sources & Laser Safety

Index

Guide

X Axis Stages

XY Axis Stages

Z Axis Stages

XZ Axis Stages

XYZ Axis Stages

Rotation Stages

Goniometer

Tilt Stages

Vacuum

Ball Bearing Guide

Crossed Roller

Dovetail

Lapping

V Groove Screw

Others

15 x 15 mm

25 x 25 mm

40 x 40 mm

60 x 60 mm

65 x 65 mm

80 x 80 mm

100 x 100 mm

120 x 120 mm

Others

Specifications

Part Number	METRIC	TSD-605CL	TSD-605SL	TSD-655CL-M6	TSD-655SL-M6
	INCH	—	—	—	TSD-655CLUU
(Opposite Model)	METRIC	—	TSD-605SRL	—	TSD-655SRL-M6
	INCH	—	—	—	TSD-655SRLUU
Stage Size [mm]		60x60	60x60	65x65	65x65
Axes of Travel		XYZ axis			
Micrometer Position		Center	Side	Center	Side
Travel [mm]		XY axis ±6.5 Z axis ±6.5	XY axis ±6.5 Z axis ±6.5	XY axis ±6.5 Z axis ±6.5	XY axis ±6.5 Z axis ±6.5
Lead of Actuator [mm/rotation]		0.5	0.5	0.5	0.5
Micrometer Readable Resolution [mm]		0.01	0.01	0.01	0.01
Guide Method		Extended contact ball bearing guide			
Primary Material		Steel			
Finish		Super black chrome			
Load Capacity [N]		49 (5.0kgf)	49 (5.0kgf)	49 (5.0kgf)	49 (5.0kgf)
Travel Accuracy	Straightness [μm]	1	1	1	1
	Pitch [N·m]	8.0	8.0	8.0	8.0
Max. Moment Capacity	Roll [N·m]	8.0	8.0	8.0	8.0
	Pitch [°/N·cm]	0.58	0.58	0.58	0.58
Options		FP	FP	FP	FP
Weight [kg]		1.7	1.7	1.9	1.9

Option

Option Code	Compatible product		Lead of Actuator [mm/rotation]	Micrometer Readable Resolution [mm]	Reference ▶
	Products Name	Part Number			
FP	Fine-pitch Screw Adjusters	FPSA-62540	0.25	—	E008

* Please add an option code as the part number suffix to specify various optional specifications.

* The FP type requires a hex wrench or the optional hex wrench with knob (KCL) for driving operation. [Reference](#) F010 [Catalog Code](#) W8008



Outline Drawing

TSD-605CL Hexagonal socket head cap screw M4x6...4 screws

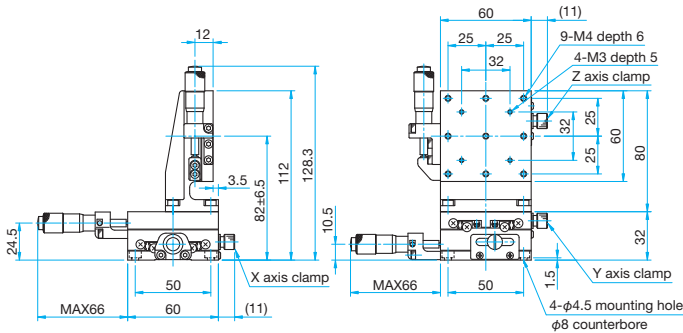

TSD-605SL Hexagonal socket head cap screw M4x6...4 screws

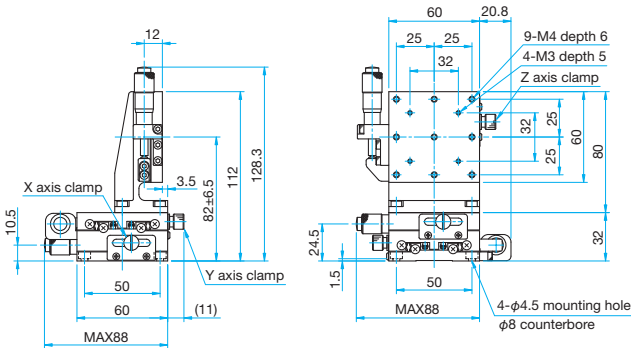

TSD-605SRL Hexagonal socket head cap screw M4x6...4 screws

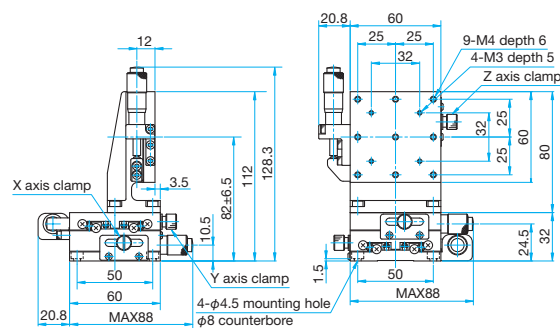

TSD-655CL-M6/655CLUU Hexagonal socket head cap screw M6x6...4 screws (M6)
Hexagonal socket head cap screw 1/4-20UNCx1/4...4 screws (UU)

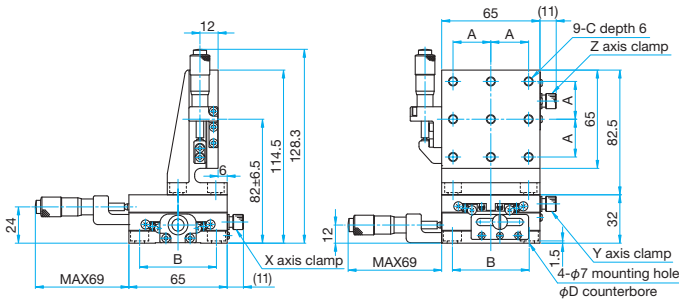

Part Number	A (mm)	B (mm)	C	D (mm)
TSD-655CL-M6	25	50	M6 P1	11
TSD-655CLUU	25.4	50.8	1/4-20UNC	12

TSD-655SL-M6/655SLUU

Hexagonal socket head cap screw M6x6...4 screws (M6)
Hexagonal socket head cap screw 1/4-20UNCx1/4...4 screws (UU)

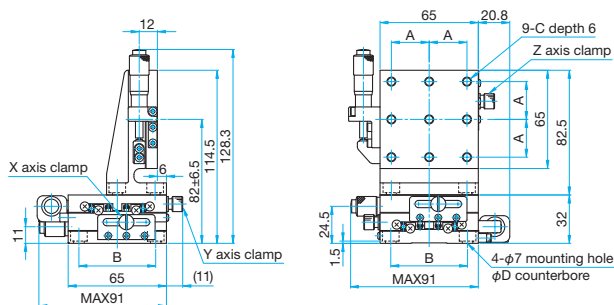

Part Number	A (mm)	B (mm)	C	D (mm)
TSD-655SL-M6	25	50	M6 P1	11
TSD-655SLUU	25.4	50.8	1/4-20UNC	12

TSD-655SRL-M6/655SRLUU

Hexagonal socket head cap screw M6x6...4 screws (M6)
Hexagonal socket head cap screw 1/4-20UNCx1/4...4 screws (UU)

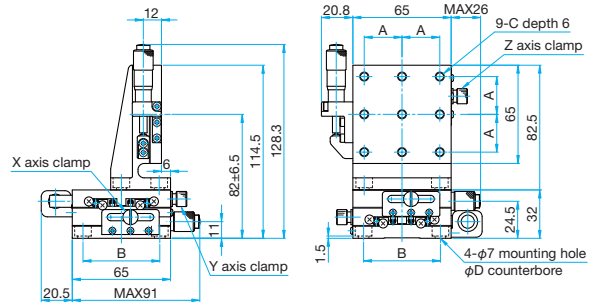

Part Number	A (mm)	B (mm)	C	D (mm)
TSD-655SRL-M6	25	50	M6 P1	11
TSD-655SRLUU	25.4	50.8	1/4-20UNC	12

Application Systems

Optics & Optical Coatings

Opto-Mechanics

Bases

Manual Stages

Actuators & Adjusters

MotORIZED Stages

Light Sources & Laser Safety

Index

Guide

X Axis Stages

XY Axis Stages

Z Axis Stages

XZ Axis Stages

XYZ Axis Stages

Rotation Stages

Goniometer

Tilt Stages

Vacuum

Ball Bearing Guide

Crossed Roller

Dovetail

Lapping

V Groove Screw

Others

15 x 15 mm

25 x 25 mm

40 x 40 mm

60 x 60 mm

65 x 65 mm

80 x 80 mm

100 x 100 mm

120 x 120 mm

Others