

# XYZ Axis Stainless Steel Extended Contact Slide Stages

Stage Size 25 × 25 mm / 40 × 40 mm / 60 × 60 mm / 65 × 65 mm

TSDS-5

RoHS

XYZ axis Stainless Steel Linear Stages suitable for hard vacuum and clean room applications. Same design and performance as TSD stages.

Completely made of stainless steel for excellent corrosion resistance.

Both the stage and the stainless steel micrometer head are lubricated with a high grade vacuum grease (YVAC2).

- Application Systems
- Optics & Optical Coatings
- Opto-Mechanics
- Bases

Manual Stages

Actuators & Adjusters

MotORIZED Stages

Light Sources & Laser Safety

Index

Guide

X Axis Stages

XY Axis Stages

Z Axis Stages

XZ Axis Stages

XYZ Axis Stages

Rotation Stages

Goniometer

Tilt Stages

Vacuum

Ball Bearing Guide

Crossed Roller

Dovetail

Lapping

V Groove Screw

Others

15 × 15 mm

25 × 25 mm

40 × 40 mm

60 × 60 mm

65 × 65 mm

80 × 80 mm

100 × 100 mm

120 × 120 mm

Others



Guide

- ▶ The TSDS series stages are suitable for use in clean rooms or vacuum applications.
- ▶ **Reference** ▶ Vacuum measurement data E205
- ▶ Also ideal for use in airtight spaces that have to avoid outgassing.

Attention

- ▶ This translation stage type is not suitable for inverted use. In this condition, all load would be pulling against the spring.
- ▶ These stages use a pivot mechanism to transfer horizontal motion to vertical motion. This mechanism induces a small non-linearity between the distance the micrometer moves and the distance the stage platform moves. Contact our Sales Division for more information.
- ▶ Regarding 25 × 25mm and 40 × 40mm size stages, please do not apply heavy load toward the rotating ('yawing') direction, as it may damage the stage.



Outline Drawing

**TSDS-255C** Hexagon socket head cap screw (stainless steel construction) M2×4...4 screws

**TSDS-255S** Hexagon socket head cap screw (stainless steel construction) M2×4...4 screws

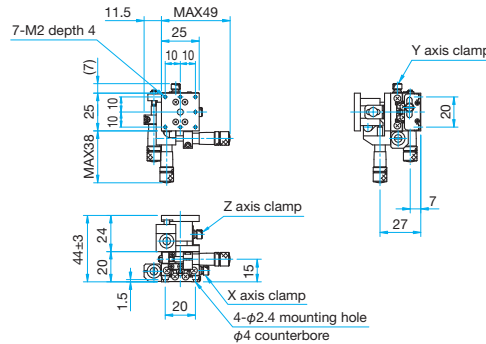
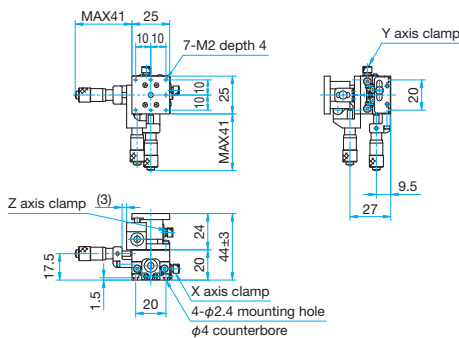

Specifications

Part Number	METRIC	TSDS-255C	TSDS-255S	TSDS-405C	TSDS-405S	TSDS-605C	TSDS-605S	TSDS-655C-M6	TSDS-655S-M6
	INCH	—	—	TSDS-405CUU	TSDS-405SUU	—	—	TSDS-655CUU	TSDS-655SUU
Stage Size [mm]		25×25	25×25	40×40	40×40	60×60	60×60	65×65	65×65
Axes of Travel		XYZ axis							
Micrometer Position		Center	Side	Center	Side	Center	Side	Center	Side
Travel [mm]		XY axis ±3 Z axis ±3	XY axis ±3 Z axis ±3	XY axis ±6.5 Z axis ±3	XY axis ±6.5 Z axis ±3	XY axis ±6.5 Z axis ±5	XY axis ±6.5 Z axis ±5	XY axis ±6.5 Z axis ±5	XY axis ±6.5 Z axis ±5
Lead of Actuator [mm/rotation]		0.5	0.5	0.5	0.5	0.5	0.5	0.5	0.5
Micrometer Readable Resolution [mm]		0.01	0.01	0.01	0.01	0.01	0.01	0.01	0.01
Guide Method		Extended contact ball bearing guide							
Primary Material		Stainless steel							
Finish		None							
Load Capacity [N]		29.4 (3.0kgf)	29.4 (3.0kgf)	88.3 (9.0kgf)	88.3 (9.0kgf)	147 (15.0kgf)	147 (15.0kgf)	147 (15.0kgf)	147 (15.0kgf)
Travel Accuracy	Straightness [μm]	5	5	2.5	2.5	2.5	2.5	2.5	2.5
Max. Moment Capacity	Pitch [N·m]	1.0	1.0	3.9	3.9	6.9	6.9	6.9	6.9
	Roll [N·cm]	1.0	1.0	3.9	3.9	6.9	6.9	6.9	6.9
Moment Stiffness	Pitch ["/N·cm]	10.55	10.55	2.5	2.5	1.0	1.0	1.0	1.0
	Roll ["/N·cm]	10.55	10.55	2.5	2.5	1.0	1.0	1.0	1.0
Parallelism [μm]		130	130	130	130	130	130	130	130
Weight [kg]		0.2	0.2	0.55	0.55	1.9	1.9	2.2	2.2



**Outline Drawing**

**TSDS-405C/405CUU**

Hexagon socket head cap screw (stainless steel construction) M3×6...4 screws, Spring washers  
Hexagon socket head cap screw (stainless steel construction) 6-32UNC×3/16...4 screws (UU)

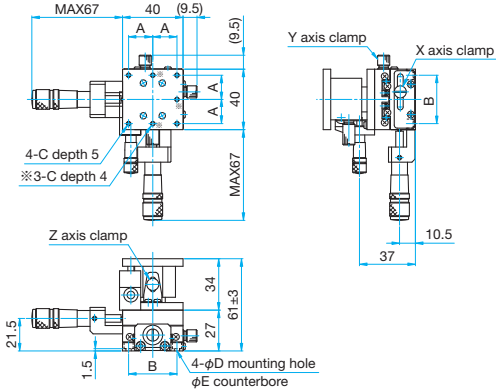

Part Number	A (mm)	B (mm)	C	D (mm)	E (mm)
TSDS-405C	16	32	M3	3.5	6
TSDS-405CUU	15.875	31.75	6-32UNC	4	6.5

**TSDS-405S/405SUU**

Hexagon socket head cap screw (stainless steel construction) M3×6...4 screws, Spring washers  
Hexagon socket head cap screw (stainless steel construction) 6-32UNC×3/16...4 screws (UU)

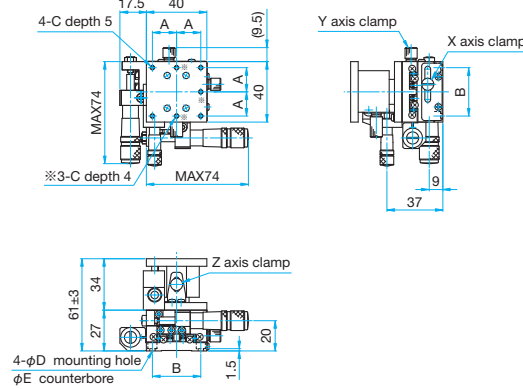

Part Number	A (mm)	B (mm)	C	D (mm)	E (mm)
TSDS-405S	16	32	M3	3.5	6
TSDS-405SUU	15.875	31.75	6-32UNC	4	6.5

**TSDS-605C** Hexagon socket head cap screw (stainless steel construction) M4×6...4 screws

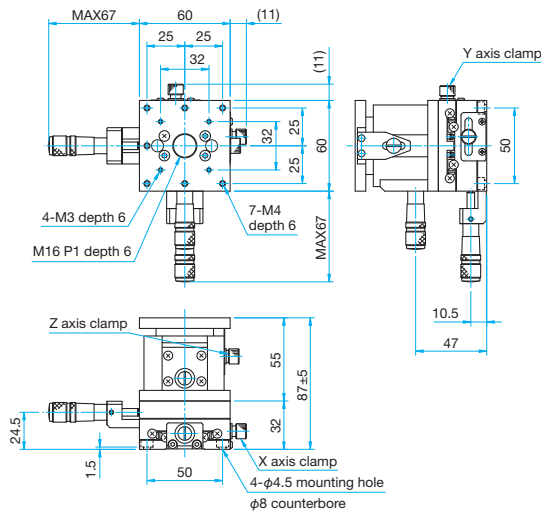

**TSDS-605S** Hexagon socket head cap screw (stainless steel construction) M4×6...4 screws

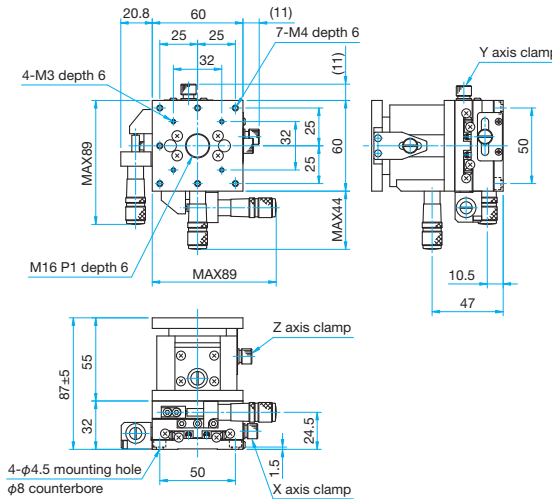

**TSDS-655C-M6/655CUU**

Hexagon socket head cap screw (stainless steel construction) M6×6...4 screws (M6)  
Hexagon socket head cap screw (stainless steel construction) 1/4-20UNC×1/4...4 screws (UU)

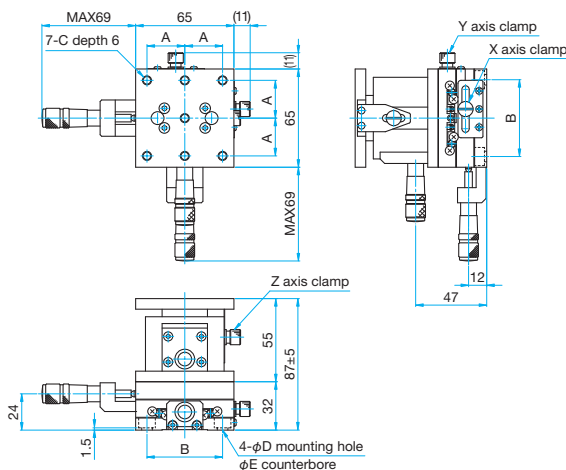

**TSDS-655S-M6/655SUU**

Hexagon socket head cap screw (stainless steel construction) M6×6...4 screws (M6)  
Hexagon socket head cap screw (stainless steel construction) 1/4-20UNC×1/4...4 screws (UU)

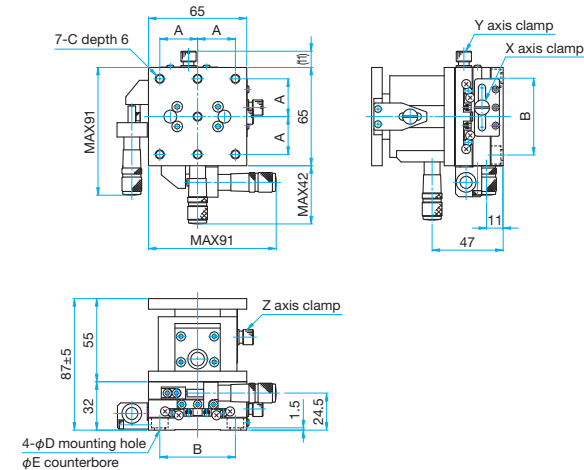

Part Number	A (mm)	B (mm)	C	D (mm)	E (mm)
TSDS-655C-M6	25	50	M6 P1	6.5	11
TSDS-655CUU	25.4	50.8	1/4-20UNC	7	12

Part Number	A (mm)	B (mm)	C	D (mm)	E (mm)
TSDS-655S-M6	25	50	M6 P1	6.5	11
TSDS-655SUU	25.4	50.8	1/4-20UNC	7	12

Application Systems

Optics & Optical Coatings

Opto-Mechanics

Bases

Manual Stages

Actuators & Adjusters

Motoeized Stages

Light Sources & Laser Safety

Index

Guide

X Axis Stages

XY Axis Stages

Z Axis Stages

XZ Axis Stages

XYZ Axis Stages

Rotation Stages

Goniometer

Tilt Stages

Vacuum

Ball Bearing Guide

Crossed Roller

Dovetail

Lapping

V Groove Screw

Ohters

15 × 15 mm

25 × 25 mm

40 × 40 mm

60 × 60 mm

65 × 65 mm

80 × 80 mm

100 × 100 mm

120 × 120 mm

Others