

Rotation stages with large Aperture | KSPB

RoHS

Low profile rotation stages offer coarse rotation adjustment of 360° and fine adjustment (with either a micrometer head or fine-pitch screw).

Directly rotate the stage upper plate for coarse adjustment, then clamp the clutch screw and use micrometer head or fine-pitch screw ($\pm 5^\circ$) for fine adjustment.



- Crossed roller bearing for high precision and high stiffness.
- Vernier scales for reading angular position.
- Center hole extends completely through stage.
- Available with micrometers or fine pitch screws.

Guide

- ▶ Most stages can be directly mounted to corresponding sized linear stages for multiple axis adjustments.
- ▶ Adapter plates are available for mounting other size stages and accessories.



Outline Drawing

KSPB-906M

Hexagonal socket head cap screw M4x8...4 screws

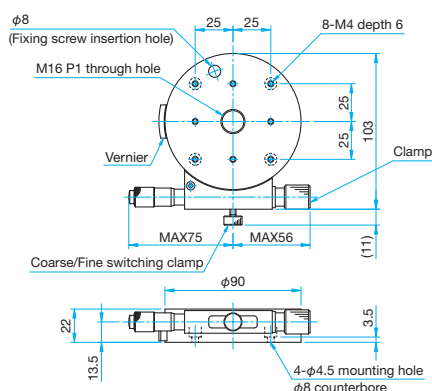

KSPB-906M-M6/906MUU

Hexagonal socket head cap screw M6x8...4 screws (M6)
Hexagonal socket head cap screw
(stainless steel construction) 1/4-20UNCx5/16...4 screws (UU)

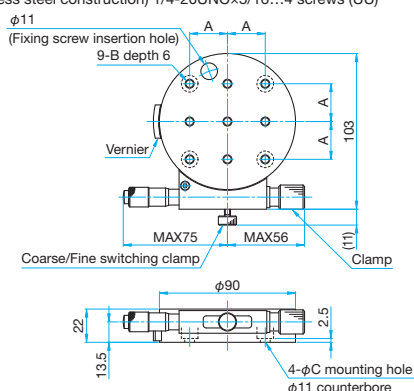

Part Number	A (mm)	B	φC (mm)
KSPB-906M-M6	25	M6 P1	φ6.5
KSPB-906MUU	25.4	1/4-20UNC	φ7

Specifications

Part Number	METRIC	KSPB-906M	KSPB-906M-M6
	INCH	—	KSPB-906MUU
Stage Size [mm]		φ90	φ90
Rotation Range [°]		Coarse: 360 Fine: ± 5	Coarse: 360 Fine: ± 5
Scale Readable Resolution		5'	5'
Micrometer Readable Resolution		about 41.25"	about 41.25"
Guide Method		Crossed roller	
Primary Material		Brass	
Finish		Super black chrome	
Load Capacity [N]		147 (15.0kgf)	147 (15.0kgf)
Max. Moment Capacity [N·m]		5.0	5.0
Moment Stiffness ["/N·cm]		0.2	0.2
Parallelism [μm]		50	50
Eccentricity [μm]		20	20
Wobble [μm]		20	20
Options		FP	FP
Weight [kg]		1.3	1.3

Option

Option Code	Compatible product		Micrometer Readable Resolution [mm]	Reference
	Products Name	Part Number		
FP	Fine-pitch Screw Adjusters	FPSA-62540	—	E008

* Please add an option code as the part number suffix to specify various optional specifications.

* The FP type requires a hex wrench or the optional hex wrench with knob (KCL) for driving operation. Reference F010 Catalog Code W8008

Application Systems

Optics & Optical Coatings

Opto-Mechanics

Bases

Manual Stages

Actuators & Adjusters

MotORIZED Stages

Light Sources & Laser Safety

Index

Guide

X Axis Stages

XY Axis Stages

Z Axis Stages

XZ Axis Stages

XYZ Axis Stages

Rotation Stages

Goniometer

Tilt Stages

Vacuum

Ball Bearing Guide

Crossed Roller

Dovetail

Lapping

V Groove Screw

Others

15 × 15 mm

25 × 25 mm

40 × 40 mm

60 × 60 mm

65 × 65 mm

80 × 80 mm

100 × 100 mm

120 × 120 mm

Others



Outline Drawing

KSPB-1206MH

Hexagonal socket head cap screw M4x8...4 screws

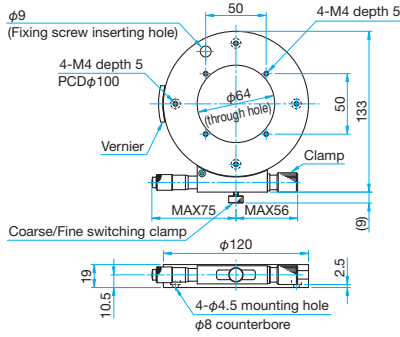

KSPB-1206MH-M6/1206MHUU

Hexagonal socket head cap screw M6x8...4 screws (M6)
Hexagonal socket head cap screw (stainless steel construction) 1/4-20UNCx5/16...4 screws (UU)

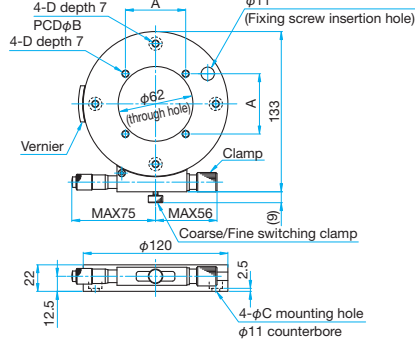

Part Number	A (mm)	φB (mm)	φC (mm)	D
KSPB-1206MH-M6	50	φ100	φ6.5	M6 P1
KSPB-1206MHUU	50.8	φ101.6	φ7	1/4-20UNC

KSPB-1606MH

Hexagonal socket head cap screw M4x8...4 screws

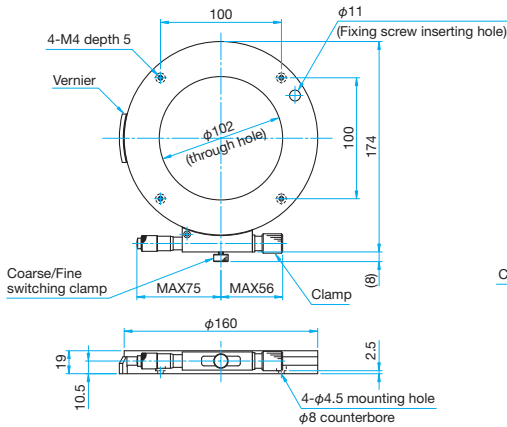

KSPB-1606MH-M6/1606MHUU

Hexagonal socket head cap screw M6x8...4 screws (M6)
Hexagonal socket head cap screw (stainless steel construction) 1/4-20UNCx5/16...4 screws (UU)

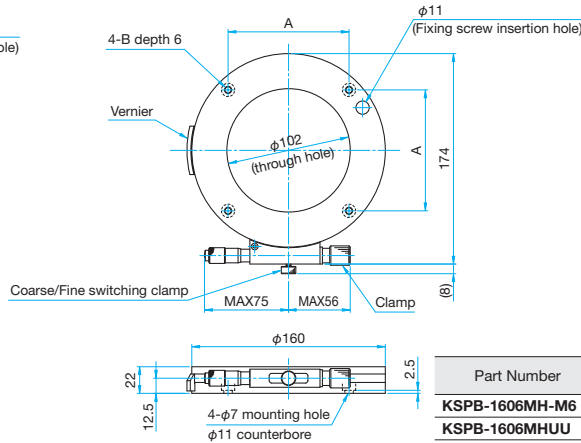

Part Number	A (mm)	B
KSPB-1606MH-M6	100	M6 P1
KSPB-1606MHUU	101.6	1/4-20UNC

Specifications

Part Number	METRIC	KSPB-1206MH	KSPB-1206MH-M6	KSPB-1606MH	KSPB-1606MH-M6
	INCH	—	KSPB-1206MHUU	—	KSPB-1606MHUU
Stage Size [mm]		φ120	φ120	φ160	φ160
Rotation Range [°]		Coarse: 360 Fine: ±4	Coarse: 360 Fine: ±4	Coarse: 360 Fine: ±3	Coarse: 360 Fine: ±3
Scale Readable Resolution		5'	5'	5'	5'
Micrometer Readable Resolution		about 31.8"	about 31.8"	about 23.7"	about 23.7"
Guide Method	Crossed roller				
Primary Material	Brass				
Finish	Super black chrome				
Load Capacity [N]		196 (20.0kgf)	196 (20.0kgf)	196 (20.0kgf)	196 (20.0kgf)
Max. Moment Capacity [N·m]		7.8	7.8	9.8	9.8
Moment Stiffness ["/N·cm]		0.1	0.1	0.1	0.1
Parallelism [μm]		50	50	50	50
Eccentricity [μm]		30	30	30	30
Wobble [μm]		20	20	20	20
Options		FP	FP	FP	FP
Weight [kg]		1.1	1.1	1.5	1.5

Option

Option Code	Compatible product		Micrometer Readable Resolution [mm]	Reference
	Products Name	Part Number		
FP	Fine-pitch Screw Adjusters	FPSA-62540	—	E008

* Please add an option code as the part number suffix to specify various optional specifications.

* The FP type requires a hex wrench or the optional hex wrench with knob (KCL) for driving operation. Reference F010 Catalog Code W8008

Application Systems

Optics & Optical Coatings

Opto-Mechanics

Bases

Manual Stages

Actuators & Adjusters

MotORIZED Stages

Light Sources & Laser Safety

Index

Guide

X Axis Stages

XY Axis Stages

Z Axis Stages

XZ Axis Stages

XYZ Axis Stages

Rotation Stages

Goniometer

Tilt Stages

Vacuum

Ball Bearing Guide

Crossed Roller

Dovetail

Lapping

V Groove Screw

Others

15 × 15 mm

25 × 25 mm

40 × 40 mm

60 × 60 mm

65 × 65 mm

80 × 80 mm

100 × 100 mm

120 × 120 mm

Others