

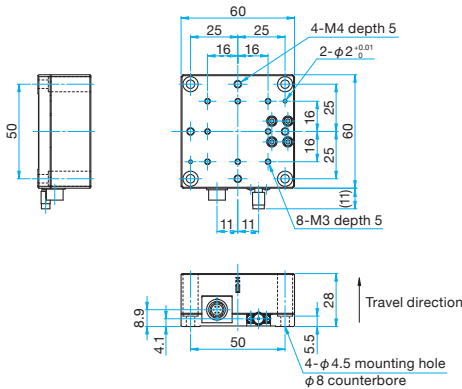

Outline Drawing

SFS-H60Z(CL) Hexagon socket head cap screw M4x10...4 screws



SFS-H60XYZ(CL) Hexagon socket head cap screw M4x10...4 screws

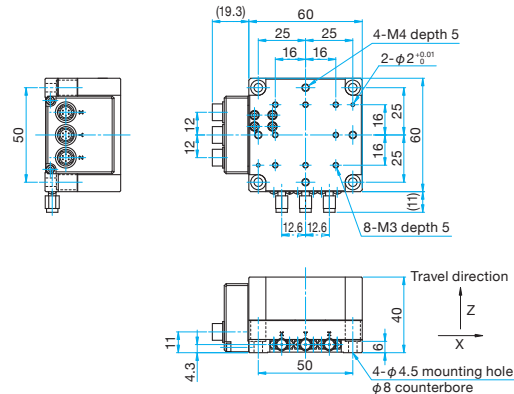

SFS-120XY(WA)

Two Axis Nanometer resolution high stiffness flexure stages with central aperture.

- High precision XY piezo stages offer high precision and high resolution positioning by utilizing full closed loop control with digital frequency based sensors.
- 50mm x 50mm aperture makes these stages ideal for microscopy applications
- Using piezo element actuators, open loop travel between 90µm – 100µm is available, with minimum incremental motion as small as 1nm.
- Closed loop travel is 80% of the open loop maximum and closed loop resolution is 10nm.
- Recommended controller is the FINE-503(**). [WEB Reference](#) [Catalog Code](#) W9057

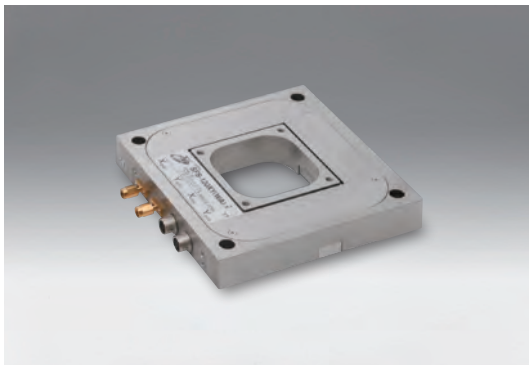

Outline Drawing

SFS-120XY(WA) Hexagon socket head cap screw M4x8...4 screws

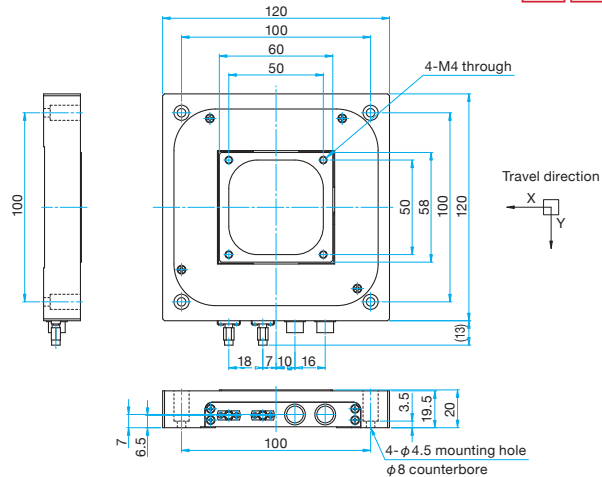

Specifications

Part Number	SFS-H60Z(CL)	SFS-H60XYZ(CL)	SFS-120XY(WA)
Travel (at open-loop control)	100µm±15%	100µm±15%	100µm±10%
Stage Size [mm]	60x60	60x60	120x120
Actuator	Piezo actuator	Piezo actuator	Piezo actuator
Weight [kg]	0.33	0.63	1.2
Theoretical Resolution (open-loop) [nm]	1	1	1
Resolution (closed-loop) [nm]	10	10	10
Linearity [%]	0.3 or lower	0.5 or lower	—
Perpendicularity (Horizontal Direction) [µm]	1	1	1 or lower
Positional Repeatability [µm]	0.1 or lower	0.15 or lower	0.1 or lower
Load Capacity [N]	9.8 (1.0kgf)	9.8 (1.0kgf)	19.6 (2.0kgf)
Micro-displacement Sensor	Digital sensor	Digital sensor	Digital sensor
Compatible Cable	FINE-CA-3: For piezo DS1-CA-3: For digital sensor	FINE-CA-3: For piezo DS1-CA-3: For digital sensor	FINE-CA-3: For piezo DS1-CA-3: For digital sensor

Application Systems

Optics & Optical Coatings

Opto-Mechanics

Bases

Manual Stages

Actuators & Adjusters

MotORIZED Stages

Light Sources & Laser Safety

Index

Guide

Controllers/Drivers

Softwares

Stepping Motor

AC Servo Motor

Cables

Piezo

X Translation

Theta Rotation

Goniometer

Vacuum

Options

40 x 40 mm

60 x 60 mm

80 x 80 mm

85 x 85 mm

100 x 100 mm

120 x 120 mm

Others

Single axis and three axis controllers for SFS series Piezo actuators.



FINE-01y



FINE-503(CL)

- Closed loop control with built in error compensation to correct hysteresis curve unique to each piezo.
- External control using a PC and manual operation with dedicated controller (CJ-200A).
- In addition to PC control and manual operation, the FINE-01y includes an analog signal input for high-speed analog control.

Part Name	Part Number
1 axis SFS Controller with Analog Input Function	FINE-01y(**)
3 axes SFS Controller	FINE-503(**)
Control Pad	CJ-200A
FINE Cable	FINE-CA-3
DS Cable	DS1-CA-3
BNC-BNC Cable	SKBNC-BNC-3.0

Primary Functions

Part Number	FINE-01y(**)	FINE-503(**)
Controller Function	<input type="radio"/>	<input type="radio"/>
Number of Control Axes	1	3
Stored Program Control	<input type="radio"/>	<input type="radio"/>
Feedback Control	Digital sensor	

General Specifications

Power Voltage	(CL) AC100V ±10% (UL) AC120V ±10% (CE) AC230V ±10% 50/60Hz
Power Consumption	50VA
Operating Temperature	10 – 30°C
Storage Temperature	-20 – 60°C
Ambient Humidity	20 – 80%RH (without condensation)
External Dimensions (WxHxDmm)	225x118x250 / 270x118x297
Weight (kg)	3.5 / 5.3

Interface

GP-IB	<input type="checkbox"/>	<input type="checkbox"/>
RS232C	<input type="checkbox"/>	<input type="checkbox"/>
USB	<input type="checkbox"/>	<input type="checkbox"/>
Analog input	<input type="checkbox"/>	<input type="checkbox"/>

Optional

CJ-200A	<input type="checkbox"/>	<input type="checkbox"/>
SKBNC-BNC-3.0	<input type="checkbox"/>	<input type="checkbox"/>

Performance Specifications

Coordinate Indication Range	±999,999nm
Max. Travel to Set	±999,999nm

Control Command

Machine Origin Return	<input type="checkbox"/>
Theoretical Origin Setting	<input type="checkbox"/>
Relative Position Drive	<input type="checkbox"/>
Absolute Position Drive	<input type="checkbox"/>
Jog Operation	<input type="checkbox"/>
Position Appointment	<input type="checkbox"/>
Circular Interpolation Control	<input type="checkbox"/>
Linear Interpolation Control	<input type="checkbox"/>
Drive	<input type="checkbox"/>
Deceleration Stop	<input type="checkbox"/>
Emergency Stop	<input type="checkbox"/>
Speed Setting	<input type="checkbox"/>
Motor Free/Hold	<input type="checkbox"/>
Port Input	<input type="checkbox"/>
Port Output	<input type="checkbox"/>

SFS Software

Free Software | SG Sample (for RS232C) Windows® Version

Free software is available to operate your controller easily from a PC. Each axis of a connected motorized stage can be moved using buttons on the screen. The software can be downloaded from our website.

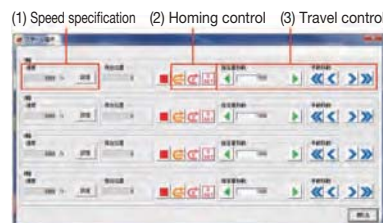

Simple operations are possible such as travel by specifying an axis, homing or jog operation.



Controllers such as SHOT-30*702 and FINE-**, which have a built-in program function, allow editing of programs from a PC. Since data can be downloaded/uploaded from/to Excel sheets, it is easy to edit programs. In addition, upload of memory switch or download mode is available.

Free Application
LabVIEW (for v.5.1/v.6i/v.7.1/v.8.6/v.2010/v.2012/v.2013/v.2014/v.2015) RS232C/GP-IB

LabVIEW application is available for LabVIEW users.

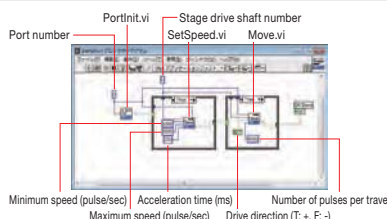

Other: 30 Day Trial Version (SGADVANCEE)

Using SGADVANCEE makes it possible to easily build measurement and control systems for a wide variety of measurement environments. Installing the trial version will require entering a serial number. The serial number for the trial version is shown on the download page.
[WEB Reference](http://www.global-optosigma.com/en_jp/software/product-download_en.html) http://www.global-optosigma.com/en_jp/software/product-download_en.html



- Application Systems
- Optics & Optical Coatings
- Opto-Mechanics
- Bases
- Manual Stages
- Actuators & Adjusters
- Motoeized Stages
- Light Sources & Laser Safety
- Index
- Guide
- Controllers/Drivers
- Softwares
- Stepping Motor
- AC Servo Motor
- Cables
- Piezo

- X Translation
- Theta Rotation
- Goniometer
- Vacuum
- Options

- 40 x 40 mm
- 60 x 60 mm
- 80 x 80 mm
- 85 x 85 mm
- 100 x 100 mm
- 120 x 120 mm
- Others