

Application Systems

Machine Vision

Manual Positions

Motion Control Products

Optical & Mirror Holder

F A Parts

Measurement & Control

FA Electrical Parts

Tool & Measure

Cleanroom & AntiStatic

Index

X Axis

XY Axis

Z Axis

XZ Axis

XYZ Axis

Rotation

Goniometers /Tilt

Multiaxis

Linear Guide

15mm

25mm

40mm

50mm

60mm

70mm

80mm

100mm

120mm

Others

Leadscrew stages with dovetail slide guide and leadscrew adjustment system, suitable for fine adjustment.

- A large adjustment knob provides good sensitivity and ease of use.



Guide

- ▶ Using the top plate spacer for TAS-2060 (SP-127-1 and SP-134) to convert mounting holes, post holders and various stages can be mounted. [Reference](#) F052, F053

Attention

- ▶ Note that the TAS-151 has no clamping mechanism.
- ▶ Micrometer brackets may extend above the top surface of some stages. Check drawings for more information.

Mounting Method

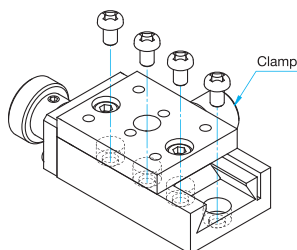

Stage must be translated to provide access to all of the mounting holes.

Specifications

		MLT11-15	MLT11-2430	MLT11-2060
Part Number		MLT11-15	MLT11-2430	MLT11-2060
Opposite Model		—	MLT11-2430R	MLT11-2060R
Table Size [mm]		15×15	24×30	18×60
Travel [mm]		±3	±4	±7.5
Screw Pitch [mm]		0.4	0.5	0.5
Positioning Slide		Dovetail method	Dovetail method	Dovetail method
Primary Material		Brass	Brass	Brass
Finish		Super black chrome	Super black chrome	Super black chrome
Load Capacity [N]		9.8 (1.0kgf)	68.7 (7.0kgf)	147 (15.0kgf)
Travel Accuracy	Straightness [μm]	20	20	20
	Pitch [N·m]	0.05	0.5	0.5
	Roll [N·m]	0.05	0.5	0.5
Moment Stiffness	Yaw [N·m]	0.02	0.5	0.7
	Pitch [°/N·cm]	—	0.51	0.25
	Roll [°/N·cm]	—	1.0	1.0
Parallelism [μm]		50	50	50
Weight [kg]		0.02	0.2	0.5



Outline Drawing

MLT11-15 Pan head screw M2x4...2 screws 2.5mm

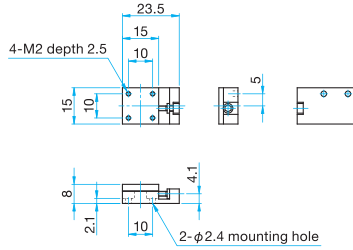

MLT11-2430 Pan head screw M3x5...4 screws

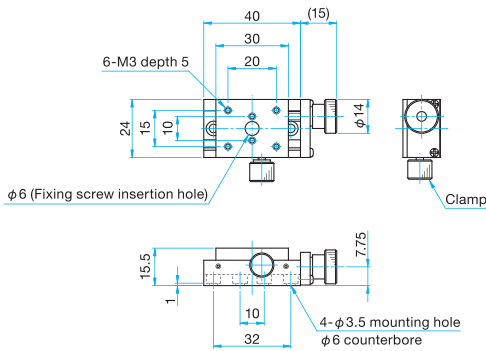

MLT11-2430R Pan head screw M3x5...4 screws

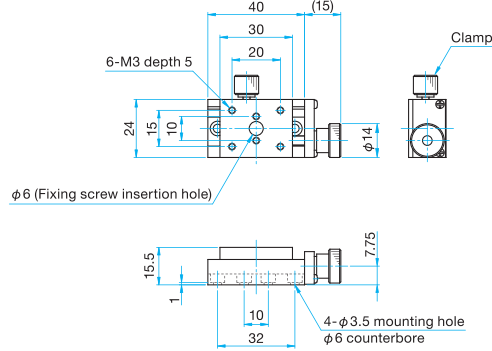

MLT11-2060 Hexagonal socket head cap screw M4x10...4 screws

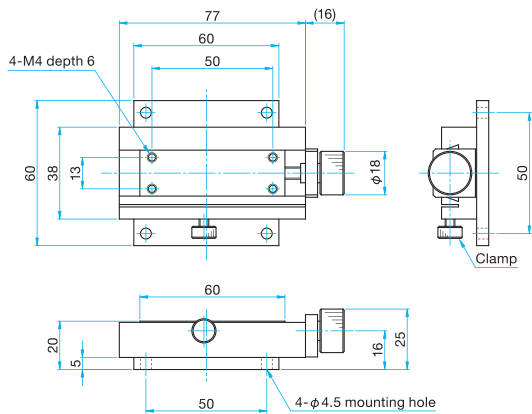

MLT11-2060R Hexagonal socket head cap screw M4x10...4 screws

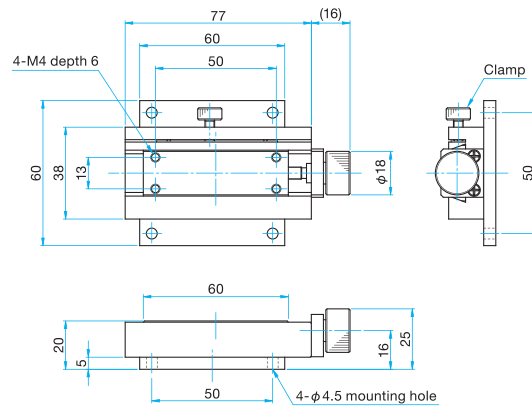

Application Systems

Machine Vision

Manual Positions

Motion Control Products

Optical & Mirror Holder

F A Parts

Measurement & Control

FA Electrical Parts

Tool & Measure

Cleanroom & AntiStatic

Index

X Axis

XY Axis

Z Axis

XZ Axis

XYZ Axis

Rotation

Goniometers /Tilt

Multiaxis

Linear Guide

□15mm

□25mm

□40mm

□50mm

□60mm

□70mm

□80mm

□100mm

□120mm

Others