

XY axis Steel Extended Contact Slide Stages (Filtered) XY axis Steel Extended Contact Slide Stages (Long)

MLT32-120 Stage size □120mm

RoHS

MLT32-1016 Stage size 100×160mm

RoHS

Hardened Steel linear stages with integrated bearing ways for superior stiffness, accuracy and durability.

- The rectangular shape minimizes the footprint while providing longer travel.

Stage □120mm

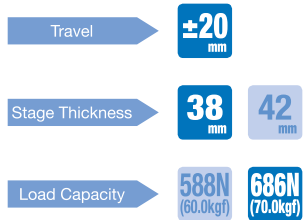

- Application Systems
- Machine Vision
- Manual Positions**
- Motion Control Products
- Optical & Mirror Holder
- FA Parts
- Measurement & Control
- FA Electrical Parts
- Tool & Measure
- Cleanroom & AntiStatic
- Index

- X Axis
- XY Axis**
- Z Axis
- XZ Axis
- XYZ Axis
- Rotation
- Goniometers /Tilt
- Multiaxis
- Linear Guide

- 15mm
- 25mm
- 40mm
- 50mm
- 60mm
- 70mm
- 80mm
- 100mm
- 120mm**
- Others

SPEC UP

Specifications		MLT32-120CH	MLT32-120SH	MLT32-1016S
Part Number		MLT32-120CH	MLT32-120SH	MLT32-1016S
Opposite Model		—	MLT32-120SRH	MLT32-1016SR
Table Size [mm]		120×120	120×120	100×160
Micrometer Position		Center	Side	Side
Travel [mm]		±20	±20	±25
Lead of Actuator [mm/rotation]		0.5	0.5	0.5
Micrometer Readable Resolution [mm]		0.01	0.01	0.01
Positioning Slide		Extended contact ball guide	Extended contact ball guide	Extended contact ball guide
Primary Material		Steel	Steel	Steel
Finish		Super black chrome	Super black chrome	Super black chrome
Load Capacity [N]		686 (70.0kgf)	686 (70.0kgf)	686 (70.0kgf)
Travel Accuracy	Straightness [μm]	1	1	1
	Pitch [ʹ]	25	25	25
	Yaw [ʹ]	15	15	15
Max. Moment Capacity	Pitch [N·m]	49	49	41.7
	Roll [N·m]	49	49	41.7
	Yaw [N·m]	27	27	19.6
Moment Stiffness	Pitch [ʹ/N·cm]	0.05	0.05	0.05
	Roll [ʹ/N·cm]	0.05	0.05	0.05
	Yaw [ʹ/N·cm]	0.06	0.06	—
Parallelism [μm]		50	50	100
Running Parallelism [μm]		25	25	30
Weight [kg]		3.1	3.1	4.8

Catalog Code W7029

Catalog Code W7030



Outline Drawing

MLT32-120CH Hexagonal socket head cap screw M4x8...4 screws

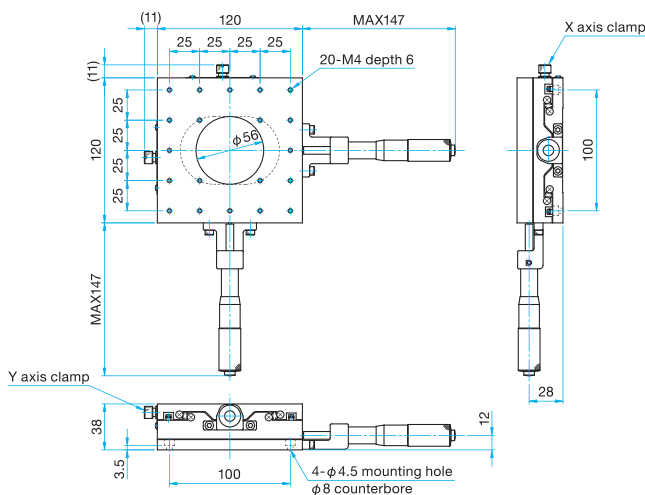

MLT32-120SH Hexagonal socket head cap screw M4x8...4 screws

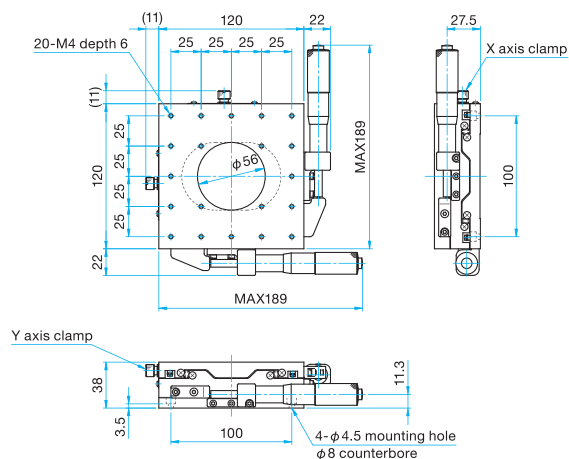

MLT32-120SRH Hexagonal socket head cap screw M4x8...4 screws

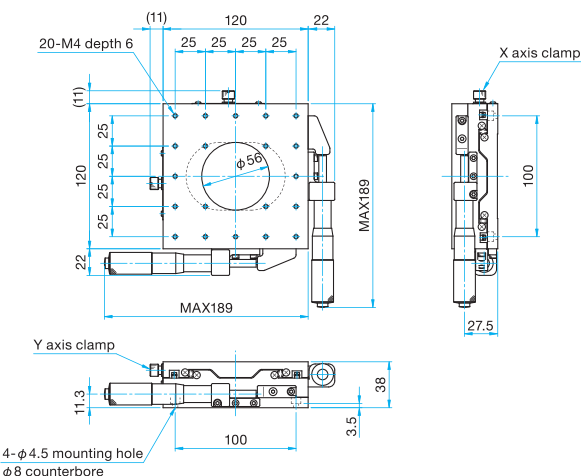

MLT32-1016S Hexagonal socket head cap screw M4x8...4 screws

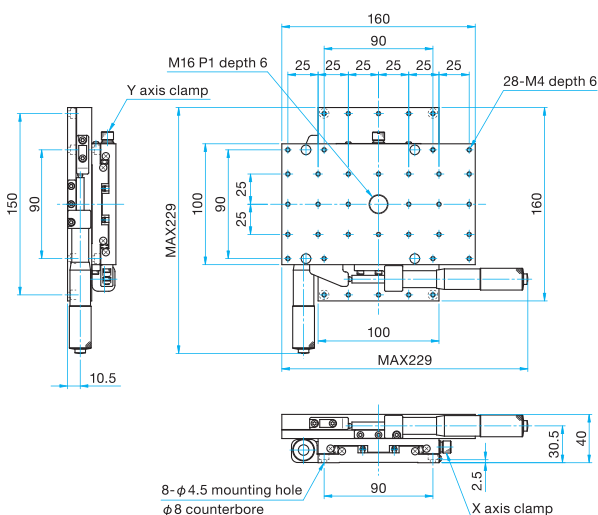

MLT32-1016SR Hexagonal socket head cap screw M4x8...4 screws

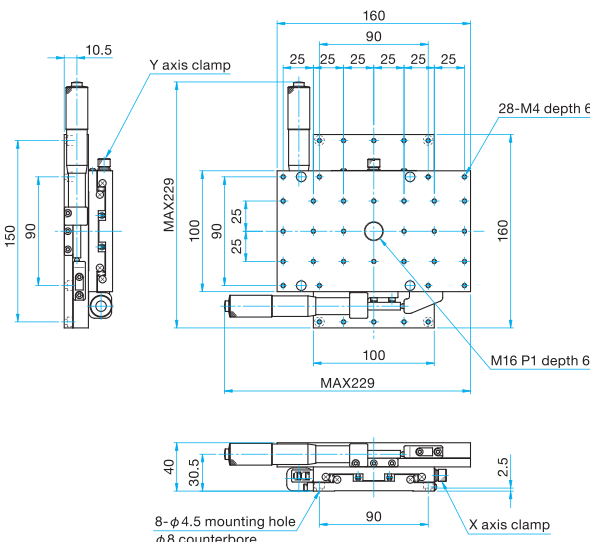

Application Systems

Machine Vision

Manual Positions

Motion Control Products

Optical & Mirror Holder

F A Parts

Measurement & Control

FA Electrical Parts

Tool & Measure

Cleanroom & AntiStatic

Index

X Axis

XY Axis

Z Axis

XZ Axis

XYZ Axis

Rotation

Goniometers /Tilt

Multiaxis

Linear Guide

□15mm

□25mm

□40mm

□50mm

□60mm

□70mm

□80mm

□100mm

□120mm

Others