

**XZ axis Stainless Steel Extended Contact Slide Stages(Vertical)**

**MLT64-L** Stage size □25/□40mm

**RoHS**

**XZ axis Stainless Steel Stages** suitable for hard vacuum and clean room applications have the same design and performance as MLT34 stages.



- Made completely of stainless steel, offering excellent corrosion resistance.
- Both the stage and micrometer head use high vacuum grease.

**Guide**

- ▶ The MLT64 series offers stages suitable for use in clean rooms or vacuum applications. [Reference](#) Vacuum measurement data G009
- ▶ Also ideal for use in airtight spaces that have to avoid outgassing.



**Outline Drawing**

**MLT64-25CL** Hexagon socket head cap screw (stainless steel construction) M2x4...4 screws

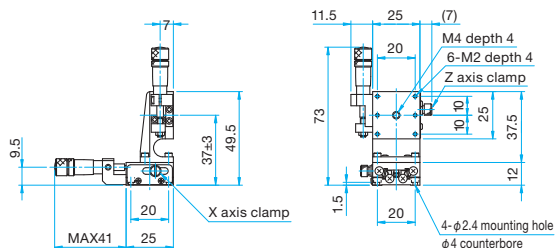

**MLT64-25SL** Hexagon socket head cap screw (stainless steel construction) M2x4...4 screws

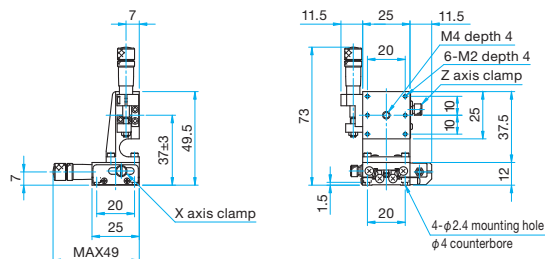

**MLT64-40CL** Hexagon socket head cap screw (stainless steel construction) M3x6...4 screws  
Spring washers

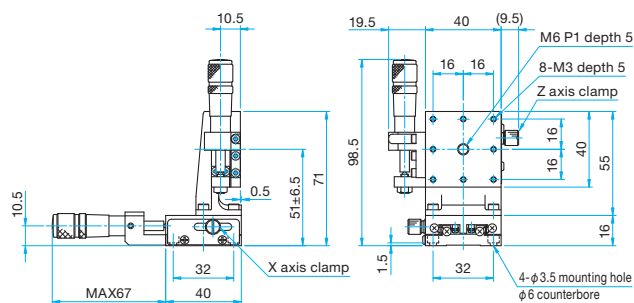

**MLT64-40SL** Hexagon socket head cap screw (stainless steel construction) M3x6...4 screws  
Spring washers

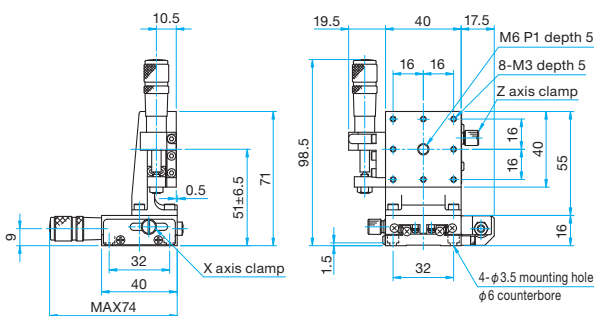

**SPEC UP**

**Specifications**

Part Number	MLT64-25CL	MLT64-25SL	MLT64-40CL	MLT64-40SL
Table Size [mm]	25x25	25x25	40x40	40x40
Micrometer Position	Center	Side	Center	Side
Travel [mm]	X axis ±3, Z axis ±3	X axis ±3, Z axis ±3	X axis ±6.5, Z axis ±6.5	X axis ±6.5, Z axis ±6.5
Lead of Actuator [mm/rotation]	0.5	0.5	0.5	0.5
Micrometer Readable Resolution [mm]	0.01	0.01	0.01	0.01
Positioning Slide	Extended contact ball guide	Extended contact ball guide	Extended contact ball guide	Extended contact ball guide
Primary Material	Stainless steel	Stainless steel	Stainless steel	Stainless steel
Finish	None	None	None	None
Load Capacity [N]	14.7 (1.5kgf)	14.7 (1.5kgf)	49 (5.0kgf)	49 (5.0kgf)
Travel Accuracy	Straightness [μm]	1	1	1
Max. Moment Capacity	Pitch [N·m]	2.2	2.2	3.9
	Yaw [N·m]	2.1	2.1	3.9
Moment Stiffness	Pitch ["/N·cm]	5.1	5.1	0.96
				0.96
Weight [kg]	0.17	0.17	0.5	0.5

**Configuration**

Part Number	MLT64-25CL	MLT64-25SL	MLT64-40CL	MLT64-40SL
Z axis	MLT63-25L	MLT63-25L	MLT63-40L	MLT63-40L
X axis	MLT61-25C	MLT61-25S	MLT61-40C	MLT61-40S

Application Systems

Machine Vision

Manual Positions

Motion Control Products

Optical & Mirror Holder

F A Parts

Measurement & Control

FA Electrical Parts

Tool & Measure

Cleanroom & AntiStatic

Index

X Axis

XY Axis

Z Axis

**XZ Axis**

XYZ Axis

Rotation

Goniometers /Tilt

Multiaxis

Linear Guide

**□15mm**

□25mm

□40mm

□50mm

□60mm

□70mm

□80mm

□100mm

□120mm

Others