

XZ axis Stainless Steel Extended Contact Slide Stages | MLT64-□ Stage size □25/□40/□60mm

RoHS

Application Systems

Machine Vision

Manual Positions

Motion Control Products

Optical & Mirror Holder

F A Parts

Measurement & Control

FA Electrical Parts

Tool & Measure

Cleanroom & AntiStatic

Index

X Axis

XY Axis

Z Axis

XZ Axis

XYZ Axis

Rotation

Goniometers /Tilt

Multiaxis

Linear Guide

15mm

25mm

40mm

50mm

60mm

70mm

80mm

100mm

120mm

Others

XZ axis Stainless Steel Stages suitable for hard vacuum and clean room applications have the same design and performance as MLT34 stages.

- Made completely of stainless steel, offering excellent corrosion resistance.
- Both the stage and micrometer head use high vacuum grease.

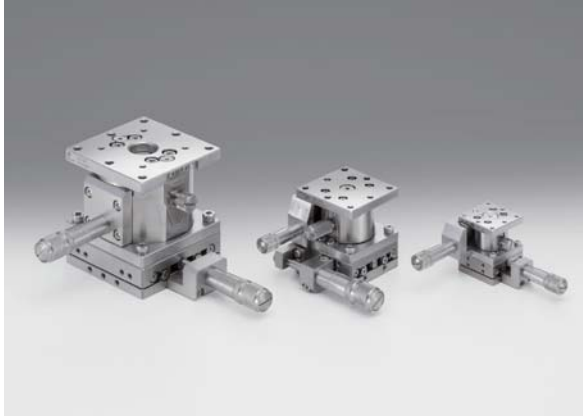

Guide

- ▶ The TSDS series offers stages suitable for use in clean rooms or vacuum applications. [Reference](#) Vacuum measurement data G009
- ▶ Also ideal for use in airtight spaces that have to avoid outgassing.

Attention

- ▶ Micrometer brackets may extend above the top surface of some stages. Check drawings for more information.

SPEC UP

Specifications							
Part Number		MLT64-25C	MLT64-25S	MLT64-40C	MLT64-40S	MLT64-60C	MLT64-60S
Table Size [mm]		25×25	25×25	40×40	40×40	60×60	60×60
Micrometer Position		Center	Side	Center	Side	Center	Side
Travel [mm]		X axis ±3 Z axis ±3	X axis ±3 Z axis ±3	X axis ±6.5 Z axis ±3	X axis ±6.5 Z axis ±3	X axis ±6.5 Z axis ±5	X axis ±6.5 Z axis ±5
Lead of Actuator [mm/rotation]		0.5	0.5	0.5	0.5	0.5	0.5
Micrometer Readable Resolution [mm]		0.01	0.01	0.01	0.01	0.01	0.01
Positioning Slide		Extended contact ball guide	Extended contact ball guide	Extended contact ball guide	Extended contact ball guide	Extended contact ball guide	Extended contact ball guide
Primary Material		Stainless steel	Stainless steel	Stainless steel	Stainless steel	Stainless steel	Stainless steel
Finish		None	None	None	None	None	None
Load Capacity [N]		29.4 (3.0kgf)	29.4 (3.0kgf)	88.3 (9.0kgf)	88.3 (9.0kgf)	147 (15.0kgf)	147 (15.0kgf)
Travel Accuracy	Straightness [μm]	5	5	2.5	2.5	2.5	2.5
Max. Moment Capacity	Pitch [N·m]	1.0	1.0	3.9	3.9	6.9	6.9
	Roll [N·m]	1.0	1.0	3.9	3.9	6.9	6.9
Moment Stiffness	Pitch [°/N·cm]	8.95	8.95	2.2	2.2	0.75	0.75
	Roll [°/N·cm]	8.75	8.75	2.15	2.15	0.75	0.75
Parallelism [μm]		110	110	110	110	110	110
Weight [kg]		0.17	0.17	0.45	0.45	1.5	1.5

Configuration							
Part Number		MLT64-25C	MLT64-25S	MLT64-40C	MLT64-40S	MLT64-60C	MLT64-60S
Z axis		MLT63-25	MLT63-25	MLT63-40	MLT63-40	MLT63-60	MLT63-60
X axis		MLT61-25C	MLT61-25S	MLT61-40C	MLT61-40S	MLT61-60C	MLT61-60S



Application Systems

Machine Vision

Manual Positions

Motion Control Products

Optical & Mirror Holder

FA Parts

Measurement & Control

FA Electrical Parts

Tool & Measure

Cleanroom & AntiStatic

Index

X Axis

XY Axis

Z Axis

XZ Axis

XYZ Axis

Rotation

Goniometers /Tilt

Multiaxis

Linear Guide

15mm

25mm

40mm

50mm

60mm

70mm

80mm

100mm

120mm

Others

Outline Drawing

MLT64-25C Hexagon socket head cap screw (stainless steel construction) M2x4...4 screws

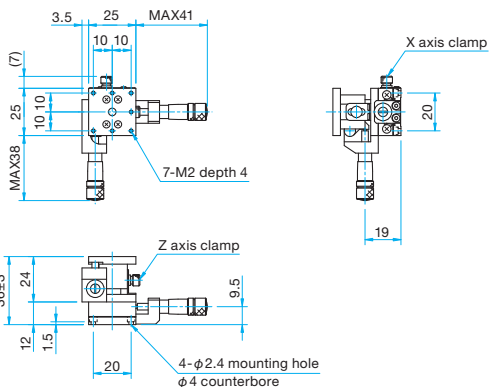

MLT64-25S Hexagon socket head cap screw (stainless steel construction) M2x4...4 screws

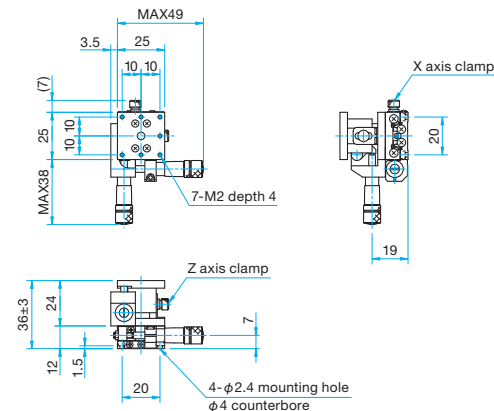

MLT64-40C Hexagon socket head cap screw (stainless steel construction) M3x6...4 screws Spring washers

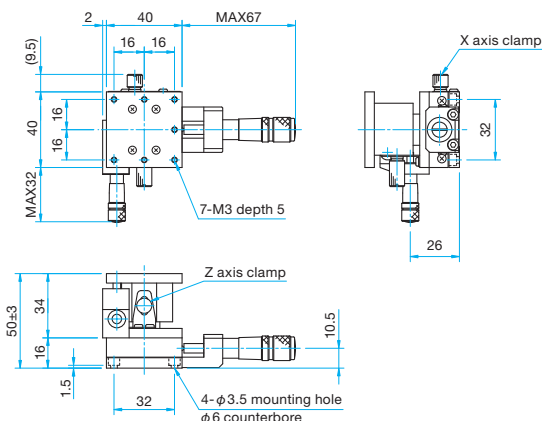

MLT64-40S Hexagon socket head cap screw (stainless steel construction) M3x6...4 screws Spring washers

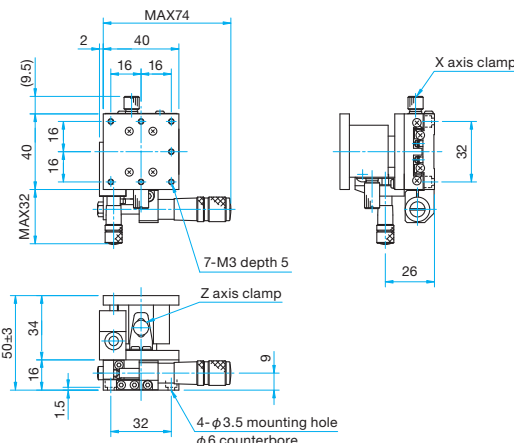

MLT64-60C Hexagon socket head cap screw (stainless steel construction) M4x6...4 screws

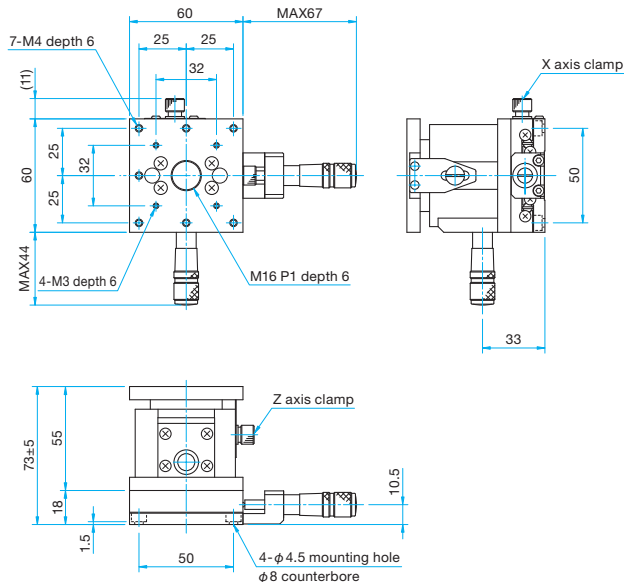

MLT64-60S Hexagon socket head cap screw (stainless steel construction) M4x6...4 screws

